

Condensation sensor

Art. no.: BTS01

Operating instructions

1 Safety instructions



Electrical devices may only be mounted and connected by electrically skilled persons.

Serious injuries, fire or property damage possible. Please read and follow manual fully.

Danger of electric shock. During installation and cable routing, comply with the regulations and standards which apply for SELV circuits.

These instructions are an integral part of the product, and must remain with the end customer.

2 Device components

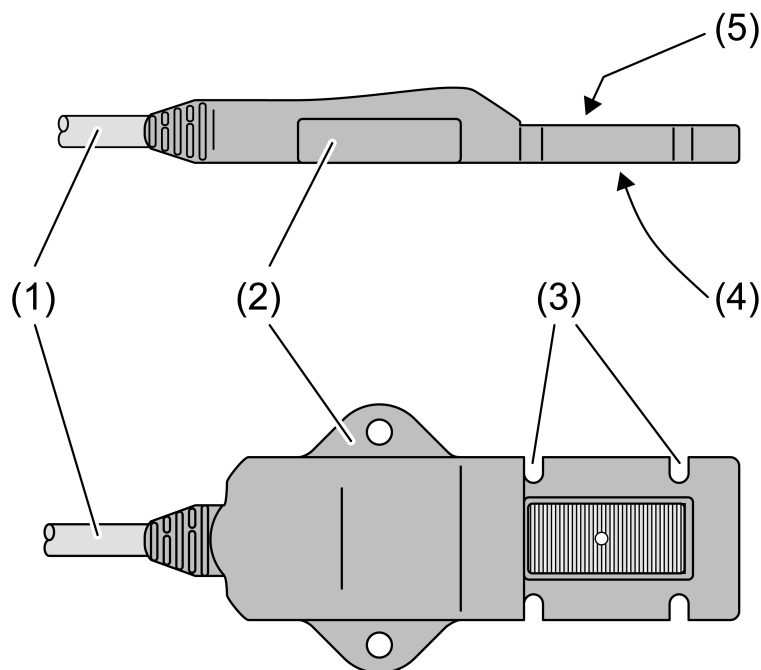

Figure 1:

- (1) Connecting cable
- (2) Fixing strap
- (3) Recession for fitting on ductwork with cable ties
- (4) Recession for a thermally conducting pad
- (5) Sensor surface

3 Function

Intended use

- Detection of water condensation on coolant lines in residential or functional buildings
- Connection to suitable binary inputs
- Fitting on the coolant line

Condensation sensor function

The device monitors the electrical conductivity between the conductive coatings on the sensor surface. If it is dampened with water, the device detects the change and signals it.

- i** The sensor surface can be damaged if it comes into contact with aggressive media (e.g. detergent solutions, scrubbing brines or acidic condensation from condensing boilers). Check the sensor area (3) every alarm. In case of significant damage from corrosion replace the device.

Cleaning instructions

Contaminations on the outer surface of the sensor can affect sensor function. Contaminations that have become wet can retain moisture, so reports can exist for a long time, as long as the condensation persists.

4 Information for electrically skilled persons

4.1 Fitting and electrical connection

Selecting installation location

The installation location should be the position that is most likely to have condensation. That can be the coldest spot within a pipeline circuit.

For proper function, the sensor surface (5) must be ventilated so that condensation can form on it.

When fitted in the vicinity of mixer valves, place the device on the colder inflow.

Fitting the condensation sensor

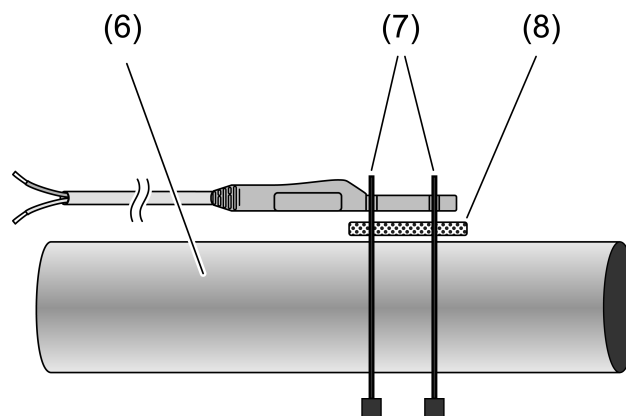

Figure 2: Fitting to a pipe with cable ties

- (6) Pipe
- (7) Cable tie
- (8) Thermally conducting pad

- Clean the outer surface of the pipe. Remove any existing remaining paint.
- Remove the protective film from the enclosed thermally conducting pad.
- Put the self-sticking thermally conducting pad (8) in the recession for the thermally conducting pad (4) and slightly press on.
The thermally conducting pad adheres to the recession on the bottom side of the device.
- Place the bottom side of the device directly on the pipe that is to be monitored.
- Fit the device to the pipe with the accompanying cable ties (7).
- Lock the connection cable into position.

Connecting the condensation sensor

The device is connected to an evaluation unit and supplied by it.

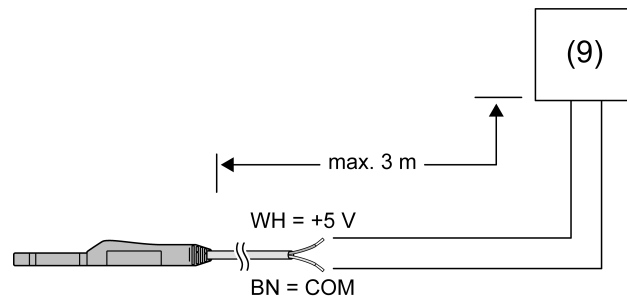

Figure 3

- Connect the device to an evaluation unit (9) that supplies and monitors the device.
- Observe the polarity:
White = +
Brown = - / COM

4.2 Commissioning

Debounce time of the evaluation unit to be set:

The ideal debounce time for this sensor is 138 ms. If this debounce time cannot be set, the maximum possible debounce time should be set.

If the dew point/leakage sensor is parameterised in the evaluation unit under “Functionality of the inputs”, the debounce time is set automatically.

5 Technical data

Rated voltage	DC 3.3 ... 5 V SELV
Current consumption	typ. 0.5 mA
Short-circuit current	max. 100 mA
Protection class	III
Ambient temperature	0 ... +50 °C
Storage/transport temperature	-40 ... +100 °C
Connecting cable	2 m
Degree of protection	IP 67

6 Warranty

The warranty is provided in accordance with statutory requirements via the specialist trade.

ALBRECHT JUNG GMBH & CO. KG

Volmestraße 1
58579 Schalksmühle
GERMANY

Telefon: +49 2355 806-0
Telefax: +49 2355 806-204
kundencenter@jung.de
www.jung.de