

Product documentation

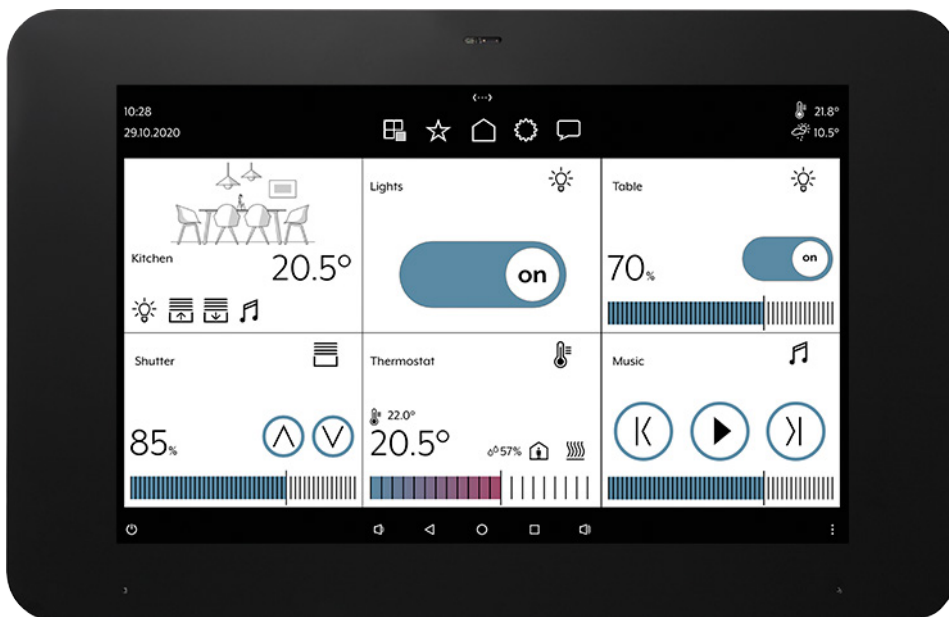

KNX Smart Panel 8

Art. no.: SP 0081 U

ALBRECHT JUNG GMBH & CO. KG

Volmestraße 1
58579 Schalksmühle
GERMANY

Tel. +49 2355 806-0
Fax +49 2355 806-204
kundencenter@jung.de
www.jung.de

Table of contents

1	Safety instructions and device components	4
1.1	Safety instructions	4
1.2	Device components	4
2	Function	4
2.1	System information	4
2.2	Intended use	4
2.3	Product characteristics	5
2.4	Included in delivery	5
2.5	Requirements	6
3	Mounting and electrical connection	6
3.1	Information for electrically skilled persons	6
3.2	Mounting in installation box or appliance box	6
3.3	Mounting the adapter	7
3.4	Connection	8
3.5	Mounting the Smart Panel	9
4	Commissioning	9
4.1	Switching on	9
4.2	Settings – Overview of the menu structure	9
4.3	Opening the settings	10
4.4	Selecting the language	10
4.5	Selecting date and time	10
4.6	Changing the system password	10
4.7	Updating the firmware	10
5	Operation	11
5.1	Operating elements	11
5.2	Control elements	12
5.3	Device settings	13
5.4	Operation using apps in the main menu	14
5.5	Apps for building automation	14
5.6	Create app link in the main menu	15
5.7	“JUNG Smart Vision” app	16
5.7.1	Status and navigation bar	17
5.7.2	Visualisation area	18
5.7.3	“Settings” menu	21

6	Configuration	23
6.1	KNX Smart Panel Designer	23
6.1.1	Downloading, installing and launching	23
6.1.2	Operation	23
6.1.3	Creating new projects or importing existing projects	24
6.1.4	Creating and configuring rooms	24
6.1.5	Creating and configuring elements	26
6.1.6	Configure time planning for an element	31
6.1.7	Configure sequences for an element	35
6.1.8	Configure advanced settings	37
6.2	ETS and DCA	61
6.2.1	Downloading and installing	61
6.2.2	Activating ETS programming mode	62
6.2.3	Deactivate "Overwrite sequences and time planning"	63
6.2.4	Exporting the configuration from the ETA via the DCA	63
6.2.5	Export configuration without DCA and ETS from the device	63
6.3	"JUNG Smart Vision" app – Advanced settings	64
6.3.1	Configure advanced settings	64
6.3.2	Configuring the presence simulation (play back, record and edit)	66
6.3.3	Configuring the sequence push-button (pairing with a physical push-button)	73
6.3.4	Pairing the Smart Panel with a mobile terminal (client)	74
6.4	"JUNG Smart Vision" app – Mobile terminal (client)	77
6.4.1	Downloading and installing	77
6.4.2	Operation	77
6.4.3	Pairing the mobile terminal (client) with the Smart Panel	77
7	Communication objects	81
7.1	Data point types	81
7.2	Elements and objects	81
8	Cleaning	94
9	Technical data	94
10	Accessories	94
11	Terms and definitions	95
12	Warranty	95

1 Safety instructions and device components

1.1 Safety instructions



Electrical devices may only be mounted and connected by electrically skilled persons.

Serious injuries, fire or property damage possible. Please read and follow manual fully.

Danger of electric shock. During installation and cable routing, comply with the regulations and standards which apply for SELV circuits.

These instructions are an integral part of the product and must remain with the end customer.

1.2 Device components

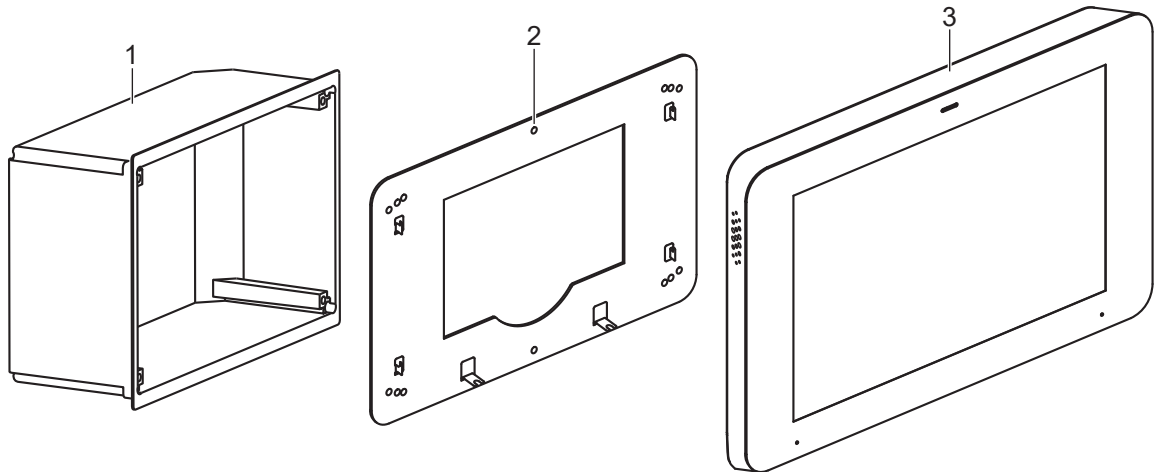

Fig. 1: Device components

- 1 Installation box
- 2 Adapter
- 3 Smart Panel

2 Function

2.1 System information

This device is a product of the KNX system and conforms to the KNX Directives. Detailed knowledge attained through KNX training is a prerequisite for understanding.

The device is planned, installed and commissioned by means of external project planning software. The latest software version and the technical descriptions can be found on our website at all times.

2.2 Intended use

- Visualising and operating system statuses and information on building automation
- Mounting horizontally (recommended) or vertically
- Mounting in a flush-mounted installation box (ref.-no. EBG 24 or SC 7 EBG) or on appliance box according to EN 60670-1 (recommendation: at a depth of approx. 60 mm)

2.3 Product characteristics

- High-resolution HD display
- Proximity sensor
- Capacitive touch screen
- Cleaning mode with touch screen lock
- Fanless, without mechanical moving parts
- Integrated bus coupling unit
- Graphical user interface for visualisation and operation of KNX devices
- Project design with the Windows software "KNX Smart Panel Designer"
- Commissioning with ETS of Version 5.7.4 or higher and DCA
- KNX special functions, e.g. scenes, sequences, central function, presence simulation
- Rooms or elements: max. 300
- Structured by multiple rooms or as single rooms
- Time planning: max. 125, each with 10 commands
- Logic operations: max. 55
- Astronomical clock
- Visualisation of the indoor and outdoor temperature
- Automatic average temperature per room
- Messages (alarm, warning, information)
- Favourites page
- Light / dark colour scheme
- Two-level configuration access (admin / user)
- User management
- User (PIN codes): max. 10
- PIN protection for rooms / elements
- Backup and restoration
- Mobile App (local access)
- App users per installation: max. 10

2.4 Included in delivery

- KNX SMART PANEL 8
- Smart Panel Adapter for wall installation
- Operating instructions

2.5 Requirements

Requirements for JUNG Smart Vision are:

- 1 x JUNG KNX Smart Panel 8
- 1 x Windows PC with JUNG KNX Smart Panel Designer Software
- 1 x ETS product data base for JUNG KNX Smart Panel 8 and corresponding DCA (Device Configuration App)

Optional:

- Local network (LAN)
- Mobile terminals (smartphone, tablet, etc.) with iOS or Android operating system

Explanation:

This manual describes the product KNX Smart Panel 8 and the JUNG SMART VISION application. JUNG Smart Vision is pre-installed as an app on the JUNG KNX Smart Panel 8 and is used to visualise and operate system statuses within the KNX building automation. A PC version of the software for Windows operating systems, the JUNG KNX SMART PANEL DESIGNER, is used for the project design and commissioning of JUNG Smart Vision. With the JUNG KNX Smart Panel Designer, you can configure the user interface of the JUNG Smart Vision App to meet your requirements. The programming of the device then takes place solely using ETS 5.7.4 and higher, as well as with the corresponding DCA (Device Configuration App within the ETS).

The JUNG KNX Smart Panel 8 is a standalone system for KNX visualisation. It plays both the client and server roles. The client role consists of allowing the control of the KNX system using graphical elements. The server role consists of managing the communication between the KNX and graphical interface in both directions. Besides the KNX visualisations JUNG Smart Vision, further JUNG apps for support, updates and the JUNG Camera app are installed.

3 Mounting and electrical connection

3.1 Information for electrically skilled persons



DANGER

Electrical shock on contact with live parts in the installation environment.

Electrical shocks can be fatal.

Before working on the device, disconnect the power and cover live parts in the area!

3.2 Mounting in installation box or appliance box

The Smart Panel is designed for mounting in a flush-mounted installation box (ref. no. EBG 24 or SC 7 EBG). The Smart Panel adapter is screwed onto the installation box.

Installation boxes from other manufacturers must match the overall dimensions and holes of the adapter and the Smart Panel. (See technical data for overall dimensions)

The installation box must be precisely aligned and mounted flush in the wall.

Alternatively, an appliance box according to EN 60670-1 can be used for mounting the Smart Panel. The Smart Panel adapter is not mounted directly on the appliance box, but on the wall.

The recommended depth of the appliance box is approx. 60 mm.

3.3 Mounting the adapter

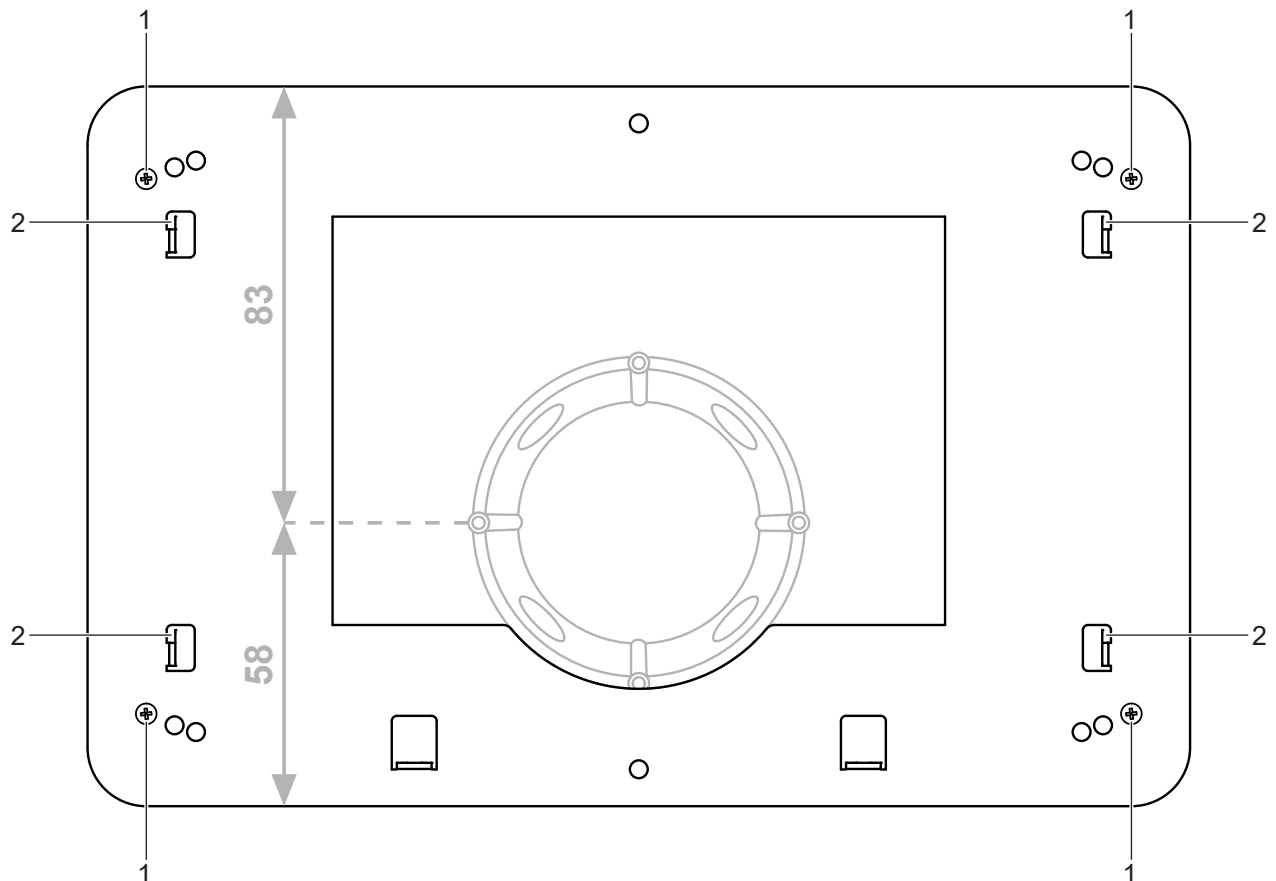

Fig. 2: Mounting the adapter

- 1 Adapter locking screw
- 2 Fixing hooks

- Mount the adapter on the installation box with a total of four locking screws (1). (fig. 2)
When mounting on an appliance box, the adapter must be mounted on the wall. The adapter must be placed in such a way that the appliance box is located in the indentation of the adapter. The appliance box is thus not located vertically in the centre of the adapter, but with a downward offset.

3.4 Connection

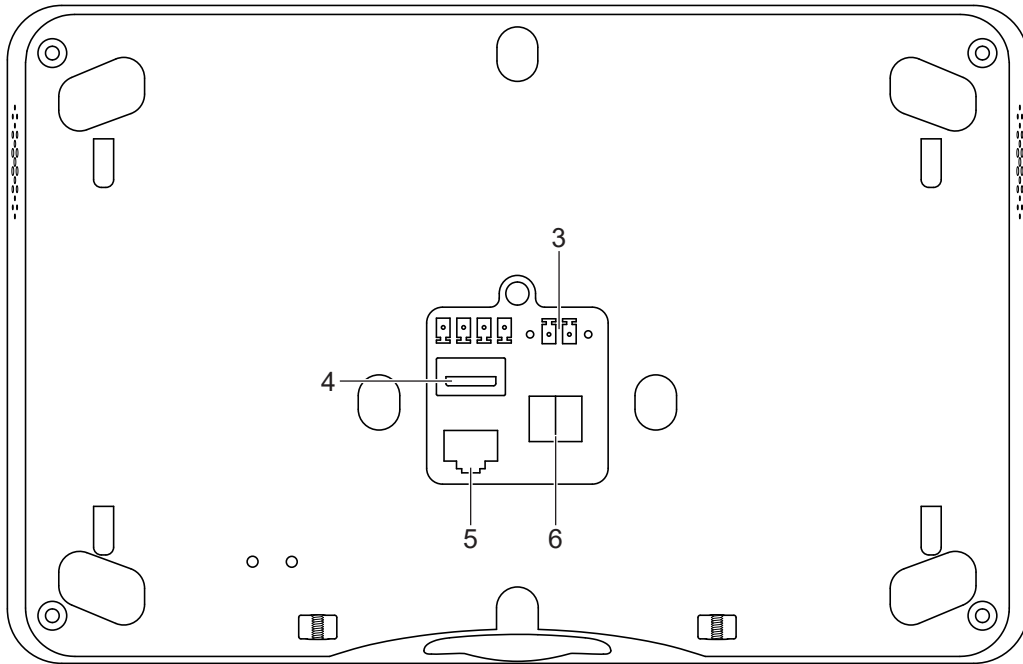

Fig. 3: Connection

3 Power supply	5 LAN/Ethernet
4 USB	6 KNX bus

Requirements:

- KNX/EIB bus connection
- Power supply via power supply adapter, ref. no.: NT 2415 REG VDC
- For firmware updates, support, IP cameras or operation via mobile end devices: Ethernet connection

- Connect the power supply (3) and KNX (6). (fig. 3)
- Connect LAN (5) optionally.

i Do not connect any other products and loads outside the KNX standard to the bus output. The bus communication could be affected by this.

3.5 Mounting the Smart Panel

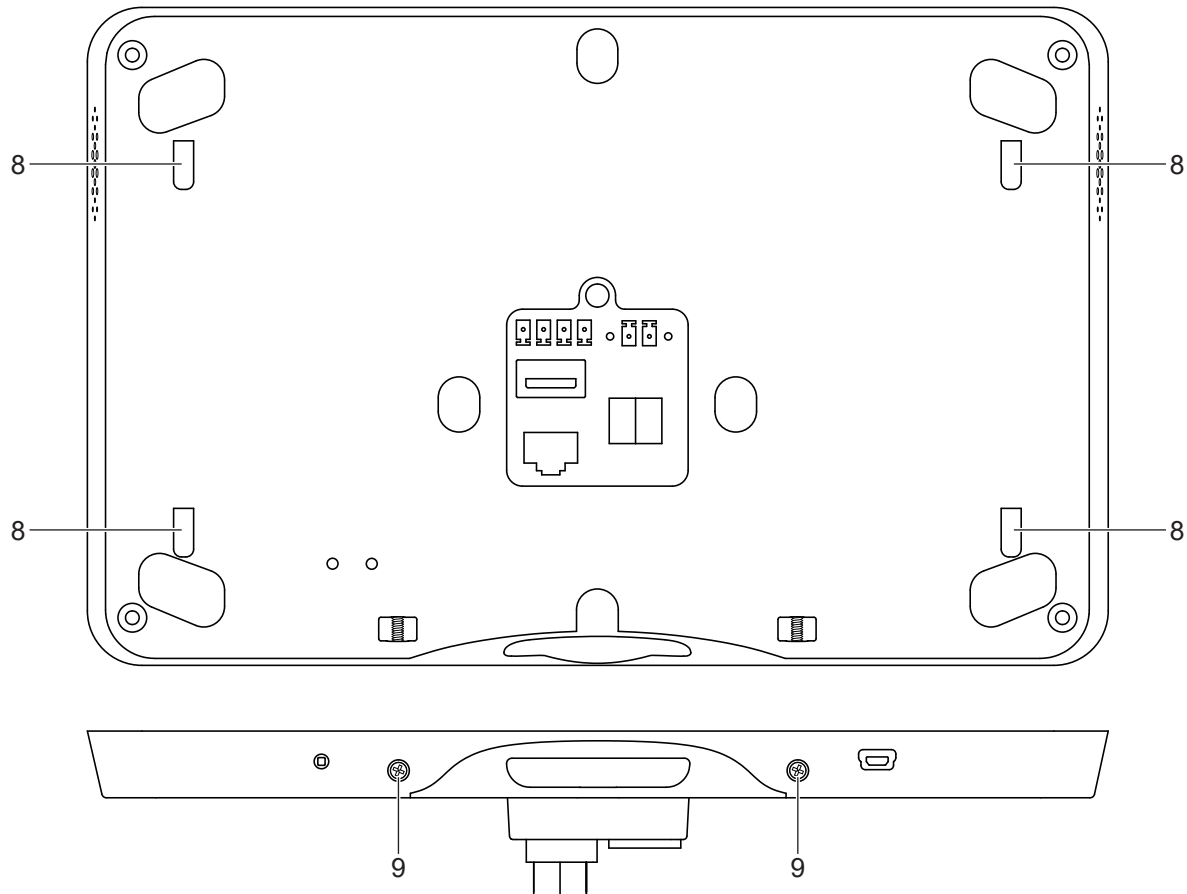

Fig. 4: Mounting the Smart Panel

- 8 Openings for wall mounting
- 9 Smart Panel locking screws

- Place the openings for wall mounting (8) on the Smart Panel on the fixing hooks (2) on the adapter. (fig. 2 and fig. 4)
To do this, place the openings for wall mounting above the hooks and engage them downwards.
- Fasten the Smart Panel to the adapter on the underside with a total of two locking screws (9). (fig. 4)

4 Commissioning

4.1 Switching on

After connecting, the device is switched on automatically and the operating system is started. After the start-up process, you must make the settings for commissioning.

4.2 Settings – Overview of the menu structure

- General
 - Language
 - Date/time
- Design
- Display
- Advanced
 - System password

4.3 Opening the settings

- Select the JUNG logo in the main menu (JUNG Launcher).
Password entry opens.
- Enter the system password.
The default system password is "0000".
The settings open.

4.4 Selecting the language

- Open the settings.
- Select the menu "General".
- Select the submenu "Language".
Available languages are displayed.
- Select the language.
The language is selected.

4.5 Selecting date and time

- Open the settings.
- Select the menu "General".
- Select the submenu "Date/time".
- Make the settings:
 - Autom. date/time: Activated
 - Autom. time zone: Deactivated
 - Select the time zone (e.g. GMT+2)
 - 24-hour format: Activated

4.6 Changing the system password

- **i** The system password grants access to all settings. The user password grants only limited access to the settings.
- Open the settings.
- Select the menu "Advanced".
- Select the "System password" submenu.
Password entry opens.
- Enter the current and new system password.
- Confirm passwords with the "OK" button.
The system password is changed.

4.7 Updating the firmware

Prerequisite: Internet connection

- Select the app "System update".
The app is started.
- Select "Search for updates online".
The firmware is updated automatically.

- **i** If there is no Internet connection, a USB storage medium can be used to update the firmware.

5 Operation

5.1 Operating elements

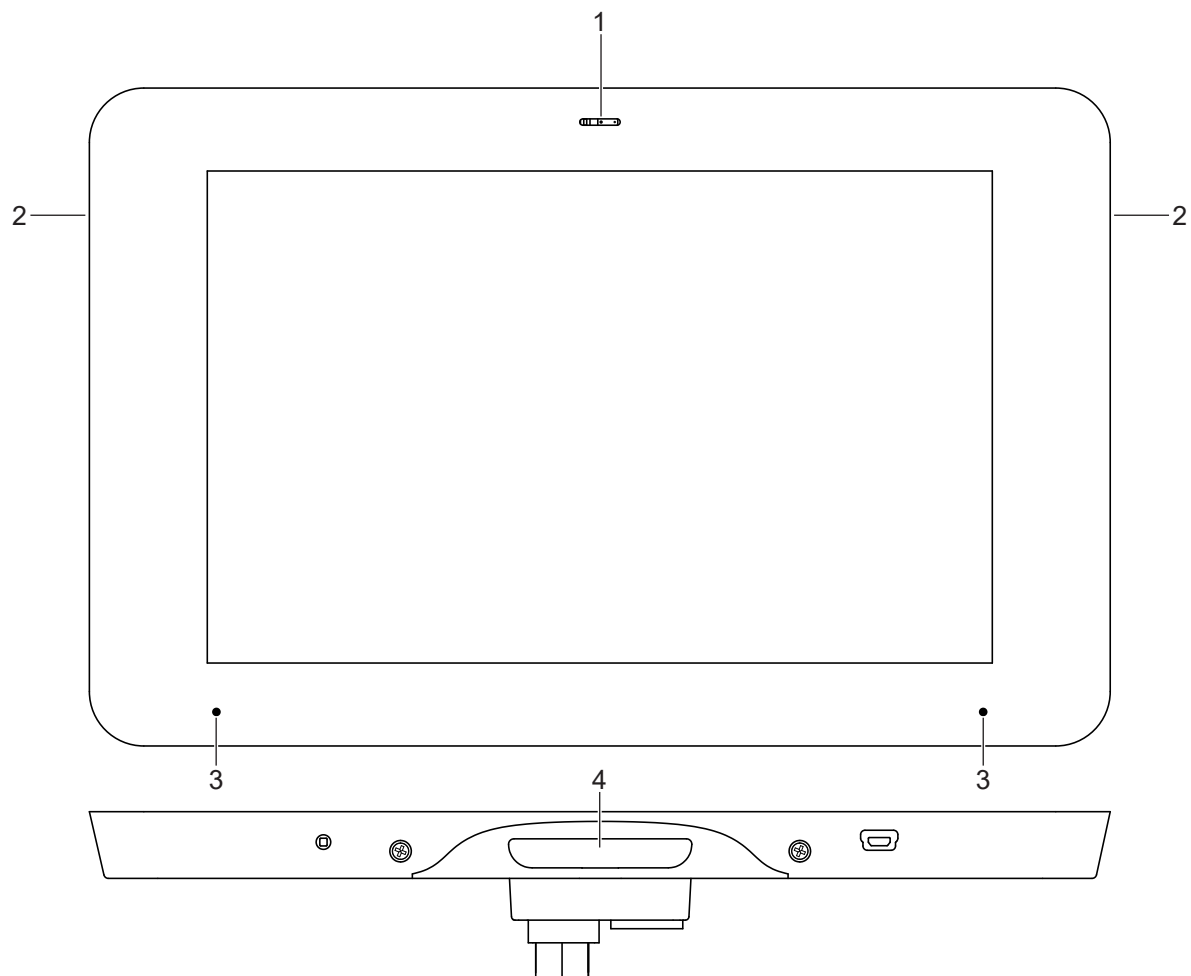

Fig. 5: Operation

	Name	Function
1	Proximity and brightness sensor	For the automatic switch-on of the display and automatic adjustment of the display brightness
2	Loudspeaker	To play signal tones
3	Microphones	To record speech
4	HOME button	To return to the main menu (JUNG Launcher) and switch the device off/on

Display main menu

- Press the HOME button briefly 1 x.
The main menu (JUNG Launcher) is displayed.

Switch device off/on

- Keep the HOME Button pressed for 5 seconds.
The operating system is powered down and the device switched off.
- Press the HOME button briefly 1 x.
The device is switched on and the operating system launches.

5.2 Control elements

Control elements are available for the operation and configuration of the device.

The control elements are not displayed in all the menu areas and apps and can be hidden as necessary.

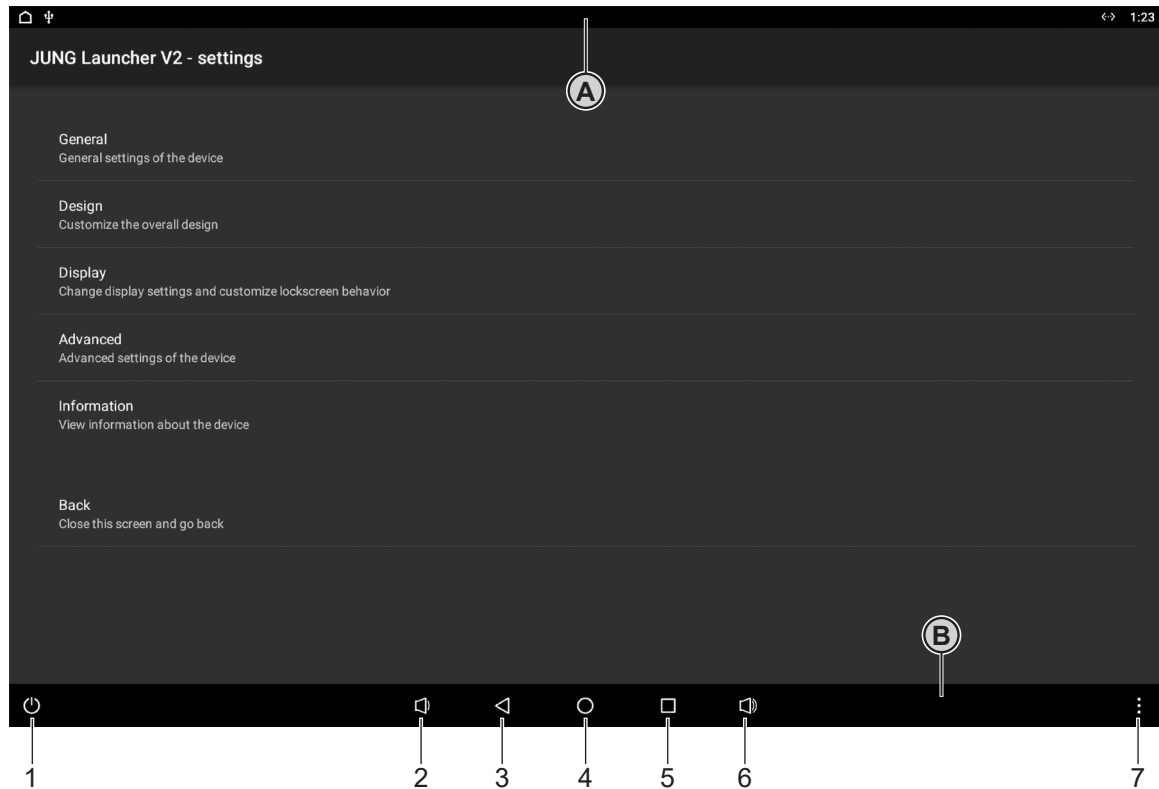

Fig. 6: Control elements

	Name	Function
A	Status bar	Display of the time Display of status messages of launched apps
B	Navigation bar	Contains basic control elements

1	Off/Restart	To restart or switch off the device
2	Quieter	To reduce the volume
3	Back	Goes back to the previous menu
4	Main menu	Goes directly to the main menu (JUNG Launcher)
5	App overview	Opens an overview of all launched apps
6	Louder	To increase the volume
7	Context menu	Opens the context menu

Opening the status bar

- Perform a swipe movement from the top edge of the touch screen to the centre
Status bar opens.

5.3 Device settings

Besides the settings for commissioning the device, additional device settings can be performed. The device settings can be opened in the main menu using the JUNG Launcher (see “Open settings” in the Commissioning chapter at page 10).

Overview of the menu structure

- General
 - Language
 - Date/time
 - Network and connectivity
 - Show navigation notification
 - Show navigation bar
 - Show virtual power button

- Design
 - Orientation
 - Theme
 - Background
 - Dashboard
 - App area

- Display
 - Display settings
 - Display power management
 - Display wake-up sensor settings
 - Adaptive brightness
 - Lockscreen

- Advanced
 - System password
 - User password
 - Welcome message
 - Autostart
 - Automatic reboot
 - App starter
 - Cache cleaner
 - App guard
 - App terminator
 - Support access
 - Config-Tool access
 - App management
 - Volume control
 - Memory
 - Account management

5.4 Operation using apps in the main menu

The device is operated via pre-installed apps.
The apps must be started via the main menu.

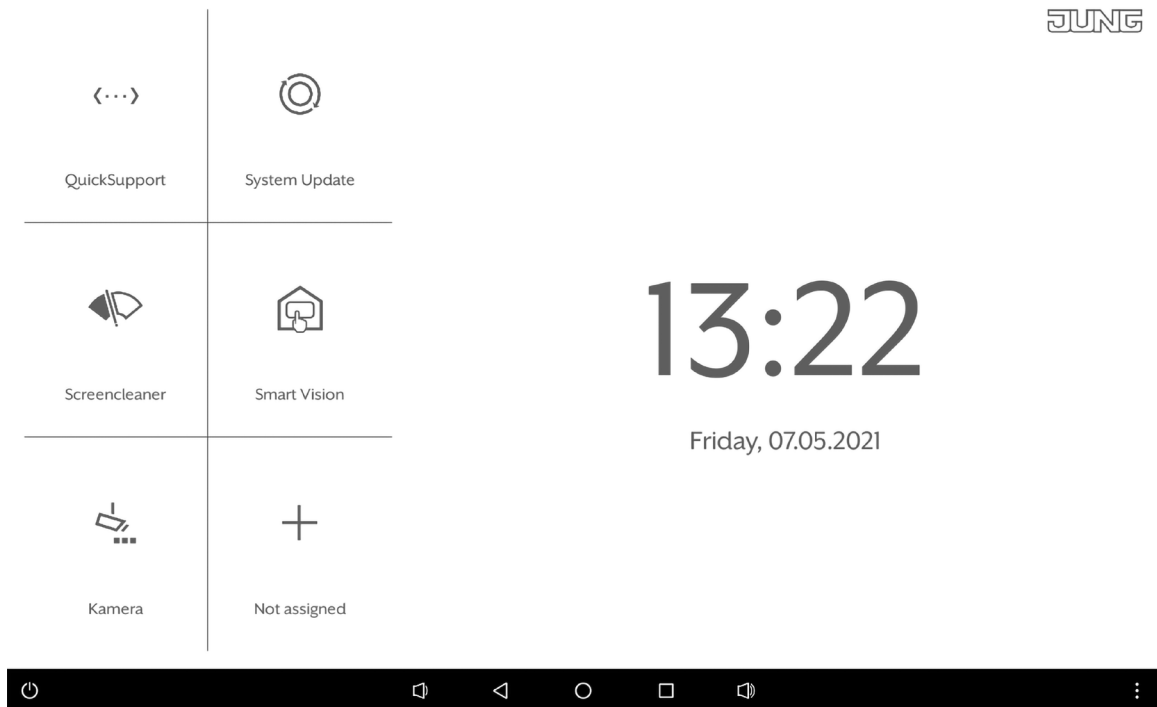

Fig. 7: Main menu (JUNG Launcher)

5.5 Apps for building automation

Software applications for building automation are already pre-installed on the device as apps.
Depending on the system used, only certain apps can be used.
The apps are used to visualise system states and to control individual components.

Pre-installed apps on the KNX Smart Panel 8:

- JUNG Smart Vision
- JUNG Camera
- QuickSupport
- System Update
- Screencleaner

- i** The device is supplied with all the apps required to control the KNX building automation. No apps from other third parties should be installed. JUNG cannot guarantee that external apps will function on the device under all circumstances. A third-party app which does not function does represent grounds for a complaint.
- i** In the delivery state, the apps JUNG Smart Vision, JUNG Camera, QuickSupport, System Update and Screencleaner are already linked in the main menu.

5.6 Create app link in the main menu

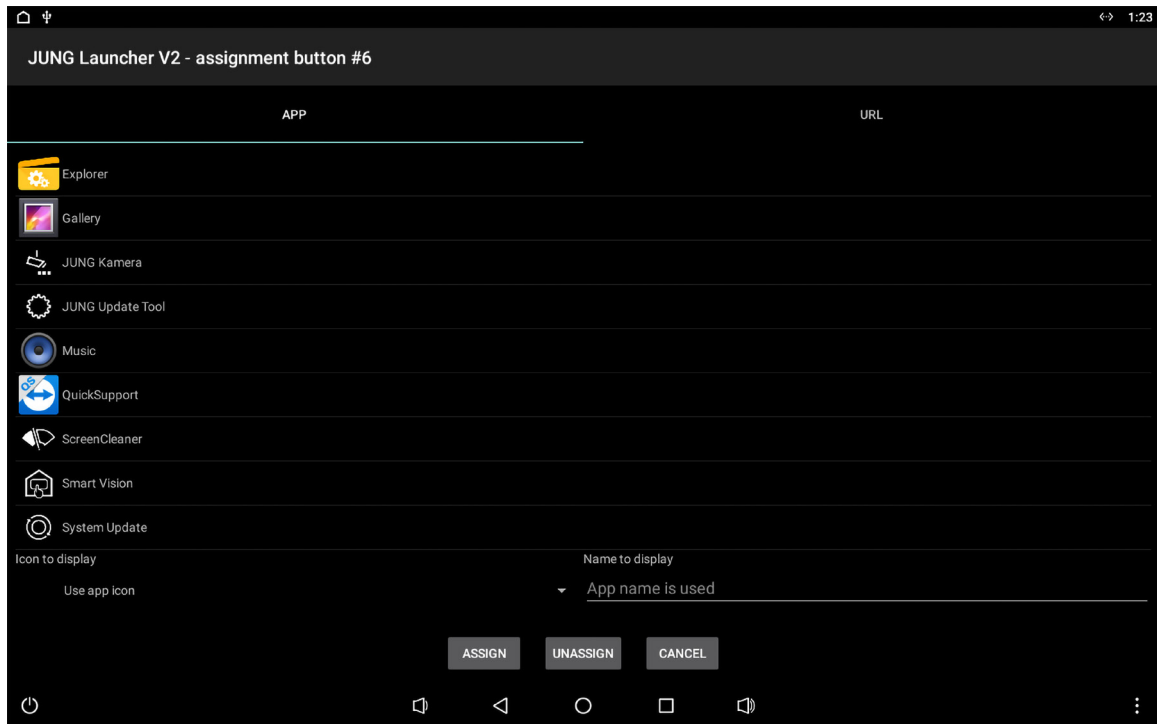

Fig. 8: Create app link in the main menu

- Touch an area/tile in the main menu for a long period of time.
The app list is displayed.
- Select an app.
A query regarding the icon and name opens.
- Change or keep the icon and name.
- Confirm the settings using the “Assign” button.
The app link is displayed in the main menu.

5.7 “JUNG Smart Vision” app

JUNG Smart Vision is pre-installed as an app on the KNX Smart Panel 8 and is used to visualise and operate system statuses within the KNX building automation.

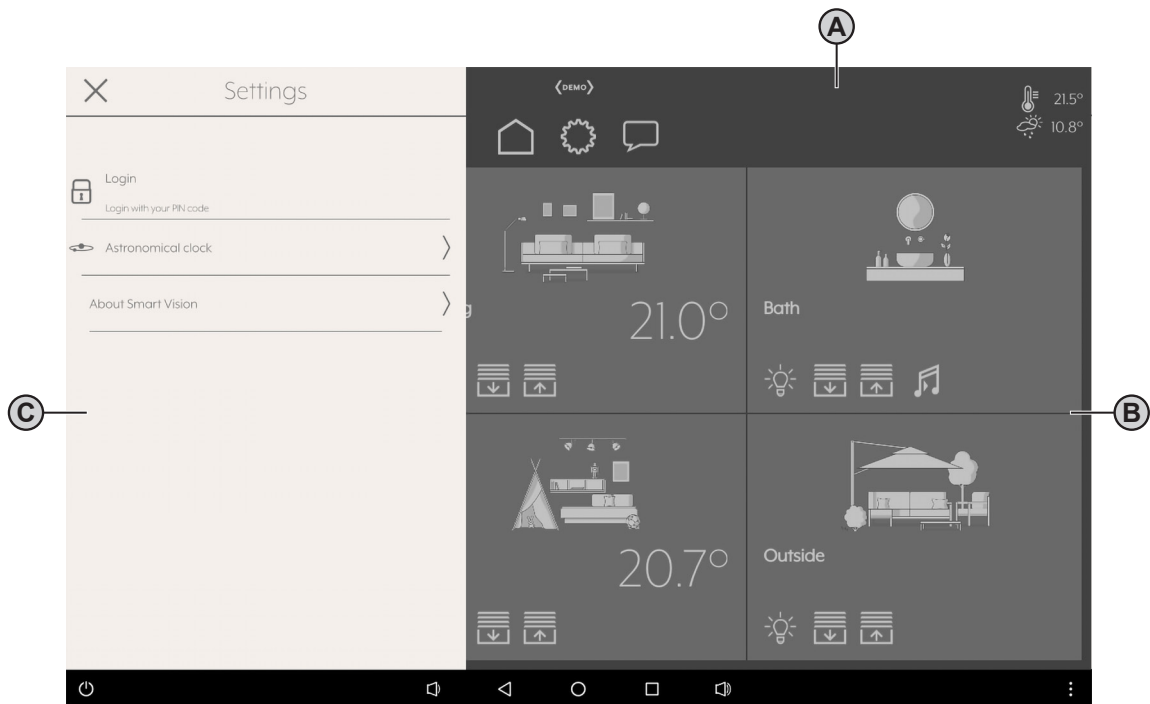

Fig. 9: “JUNG Smart Vision” app

	Name	Function
A	Status and navigation bar	Display of connection icon and status Display of max. five icons (e.g. to display menus) Display of time, date and temperature
B	Visualisation area	Room overview Selection of individual rooms
C	Menu	Display of menus (e.g. Settings)

5.7.1 Status and navigation bar

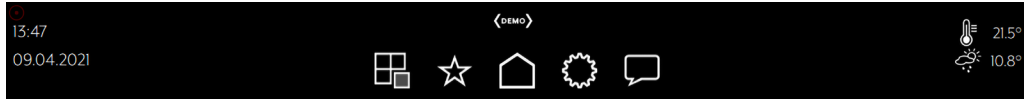

Fig. 10: JUNG Smart Vision – Status and navigation bar

Up to five navigation icons are displayed in the Status and navigation bar.

Icon	Name	Explanation
	Plugins	Extensions for special functions
	Favourites	Quick access to frequently used functions
	Home / Room view	Main menu / Overview of all rooms
	Settings	Opens the menu for app settings
	Messages	Displays current and archived messages, such as error messages

Besides the current date and time, it is also possible to display the indoor and outdoor temperatures. Both values can be linked to the ETS using communication objects.

Icon	Name	Explanation
	Indoor temperature	Actual temperature value in the room
	Outdoor temperature	Actual temperature value outside the building

The connection icon displays the current status of the connection between the Smart Vision app and the Smart Panel.

Icon	Name	Explanation
	Unknown	Status of the connection is not known or is being determined
	Offline	No connection
	Offline programming	No connection, changes will be saved locally and synchronised later
	Error	Could not set up connection
	Trying to connect	Setting up connection
	Wait for core services	Connection has been set up but the core services are not yet ready
	Connected locally	Connection available via the local network
	Demo mode	Demo project is displayed, changes will not be saved

5.7.2 Visualisation area

Here, the created rooms and/or elements of a room are displayed, along with special settings pages, such as editing time planning, the presence simulation or scenarios.

IMPORTANT:

A maximum of 300 elements (rooms or functions) can be created.

A maximum of 1,000 communication objects can be linked.

Room overview



Fig. 11: JUNG Smart Vision – Visualisation area, room overview

This view is defined as the home page of the visualisation, which can be accessed at any time using the house icon in the top bar. The first 6 rooms are shown in corresponding tiles through their name, background and central functions. Scrolling down/up gives access to other rooms. Clicking a tile gives access to the detail view of the room or a desired function.

- A maximum of 6 rooms can be displayed in a grid.
- Vertical scrolling: Navigation to other rooms
- Horizontal scrolling: Navigation to the first room (to the right) or to the last room (to the left)
- Clicking the tile: Jump to the room
- Tile central function: Bottom left (light/blind/music)

Room view

In the Room detail view, the contents of the room are displayed in a 6x6 grid. The first position shows the tile of the room itself. Further elements and functions can be reached on this level by scrolling up or down. Scrolling to the side causes the system to switch to other rooms on the same level.



Fig. 12: JUNG Smart Vision – Visualisation area, room view

- The room display shows up to 5 of the first elements of the appropriate room.
- The first element shows the room, together with its name and central functions.
- Vertical scrolling: Navigation to other elements
- Horizontal scrolling: Navigation to the next or previous room (to the right) or to the last room (to the left)
- Clicking the tile: Jump to the detail view

Central functions (only available in the room overview or room view)

Central functions can be created for each room according to requirements and the contents. These can also be operated from the this view. There is a central switch for light, blinds and music and a display of the room temperature.

These functions become available as soon as at least one element corresponding to the appropriate device type is added to the room (i.e. at least 1 x light, 1 x blind switch, 1 x thermostat or 1 x music element) AND central functions are activated in the settings for the room.

Icon	Name	Explanation
	Light	Switch light in room on / off
	Blinds down	Move all blinds in the room down
	Blinds up	Move all blinds in the room up
	Music	Play / pause music in the room
20.5°	Room temperature	Display of the actual temperature value in the room

Detail view

The detail view of an element is the lowest navigation point within the hierarchy level.

Here, each element is offered for operation with all its functions.

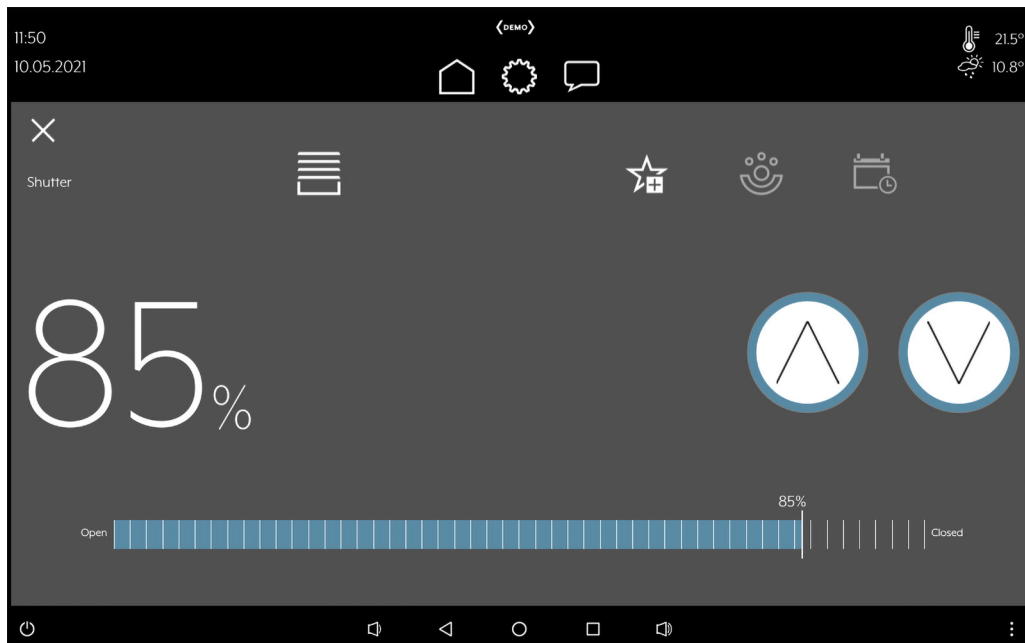

Fig. 13: JUNG Smart Vision – Visualisation area, detail view

All the elements share the following function icons (if activated):

Icon	Name	Explanation
	Time planning	Open/edit detail view for time planning
	Sequence	Open/edit detail view for sequence
	Favourite	Add element to Favourites
	Close detail view	Detail view view closed, room is displayed

5.7.3 “Settings” menu

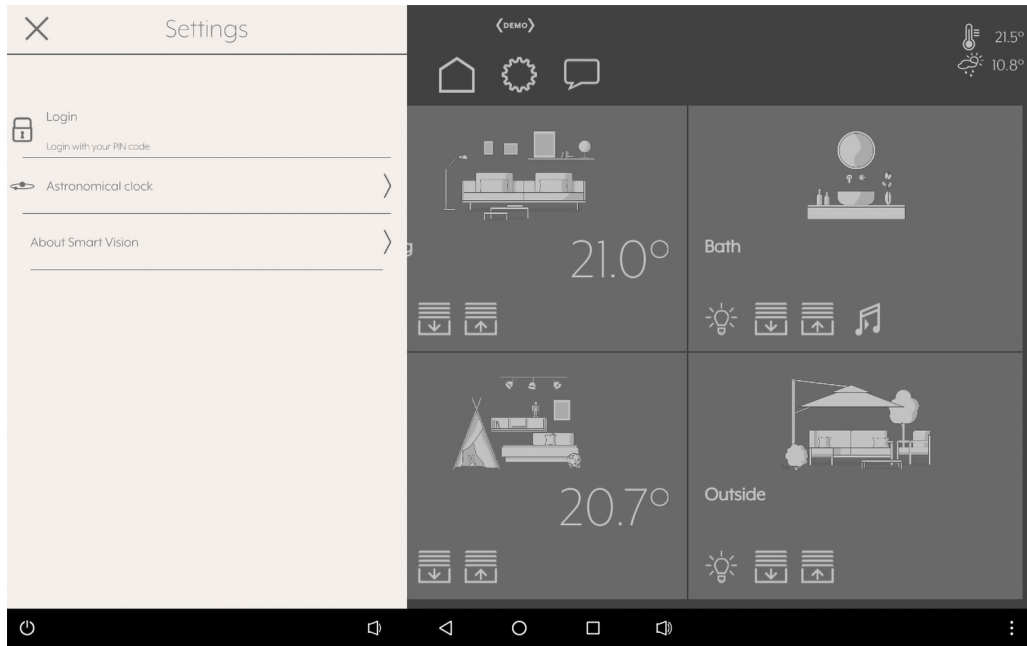

Fig. 14: JUNG Smart Vision – “Settings” menu

The menu can be opened using the cog icon in the Status and navigation bar.

Settings can only be edited or changed when logged in as an Administrator. The cog icon appears in colour if you are logged in as an Administrator or non-standard user.

Icon	Name	Explanation
	Opening the settings	The "Settings" menu is opened (press it again to close it)
	Settings as Administrator (blue icon)	The "Settings" menu is opened, log-in as an Administrator has taken place, additional functions and submenus are displayed
	Close settings	"Settings" menu is closed

Log user in as Administrator

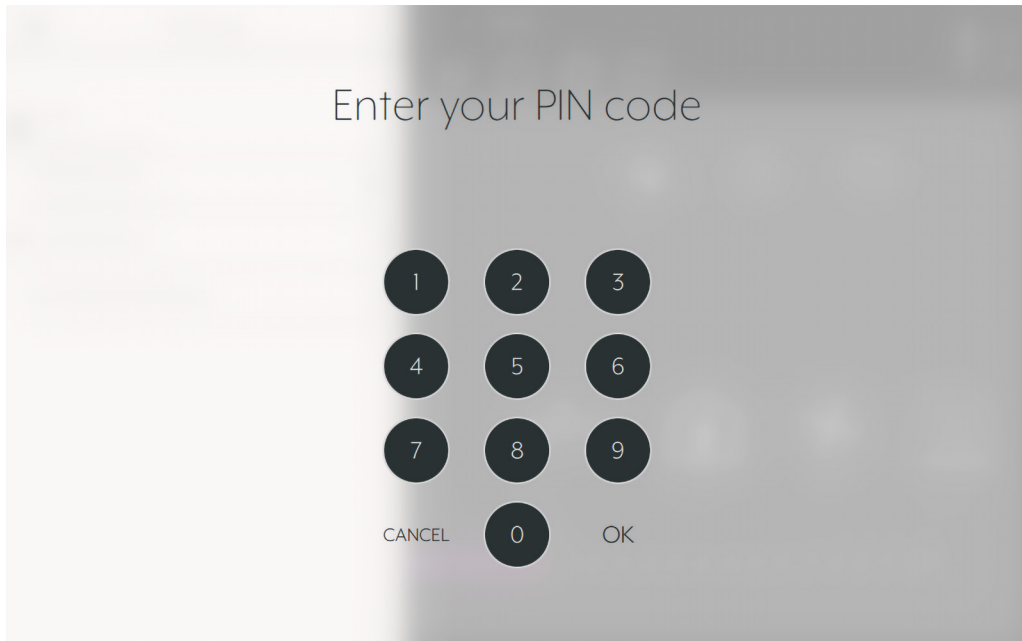

Fig. 15: JUNG Smart Vision – Password entry for log-in as an Administrator

- Select “Login” in the “Settings” menu.
Password entry opens.
- Enter the Administrator password.
The default Administrator password is: 74269
- Confirm the entry with “OK”.
User is logged in as an Administrator.
The cog icon is displayed in blue.
Advanced functions and submenus are displayed.

Log user out as Administrator

- Select “Logout” in the “Settings” menu.
User is logged out as an Administrator.
The cog icon is displayed in white (transparent).
Advanced functions and submenus are hidden.
- i** The user is logged out automatically after 15 minutes without activity.

6 Configuration

6.1 KNX Smart Panel Designer

The first step is to create the project using the KNX Smart Panel Designer. There, all the rooms, elements, time planning, scenarios, logic operations, etc. are created and edited until the desired result has been achieved. Then, this configuration is exported to a desired folder on the PC in the KNX Smart Panel Designer under “Configuration → Export/Import → Export”. The resulting project file has the ending *.ksp (see “Export/Import” submenu on page 56).

6.1.1 Downloading, installing and launching

The software is available on our website as a free download. Install the KNX Smart Panel Designer on your laptop or PC and launch the application.

IMPORTANT:

The KNX Smart Panel Designer of Version 1.0.16 or higher is required!

6.1.2 Operation

The software is operated in the same way as the “JUNG Smart Vision” app is operated.

You can find an overview of the areas of the app at page 13.

Further basic operation principles can be found here:

Open settings

Description see page 21

Log user in as Administrator

Description see page 22

The default Administrator password is: 74269

Activate configuration mode

After launching the KNX Smart Panel Designer, the user is automatically logged in as an Administrator and configuration mode is already activated. This means that manual activation of the configuration mode is not usually required.

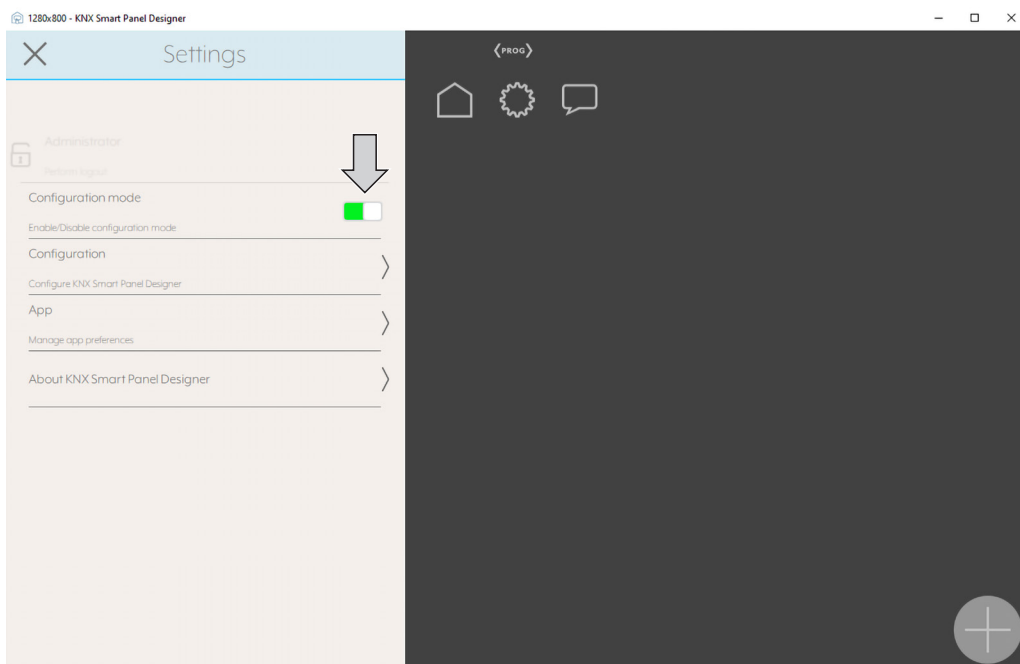

Fig. 16: Smart Panel Designer – Activate configuration mode

Precondition:

User is logged in as an Administrator.

- Activate configuration mode using the toggle switch in the “Settings” menu. The Plus icon for adding a new room or element is shown.

Icon	Name	Explanation
+	New room / new element	Add a new room / new element (configuration mode must be activated)

6.1.3 Creating new projects or importing existing projects

A new project is created on starting the KNX Smart Panel Designer. New projects do not contain any rooms, elements or functions.

Existing project files can be used as the basis for new projects. The project files with the file ending .ksp must be imported via the menu “Configuration → Export/Import → Import” (see “Export/Import” submenu on page 56).

6.1.4 Creating and configuring rooms

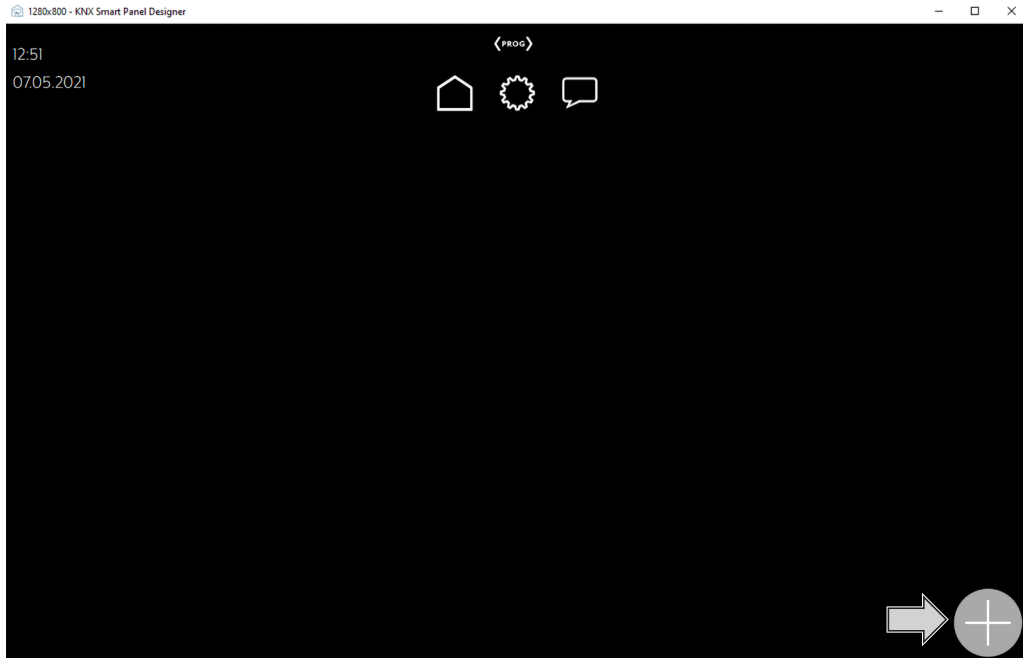

Fig. 17: Smart Panel Designer – Creating and configuring rooms

Preconditions:

User is logged in as an Administrator.

Configuration mode is activated.

- Add a new room using the Plus icon.
The “Add room” menu is displayed.

“Add room” menu

- Background image:

A room sketch can be defined for each room using “Add room → Background → Image”. Currently, 15 different room sketches are available:

i You cannot integrate your own sketches.

The library is continually being expanded and extended with future updates.

- Central functions:

For each room, various central functions (light/blind/music/room temperature) can be assigned as necessary using “Add room → Central functions”.

Description see page 19

- Visibility:

In addition, visibility is also possible for unauthorised persons, i.e. for users who are not permitted to control the central functions due to their user rights. As standard, visibility is not active for unauthorised people.

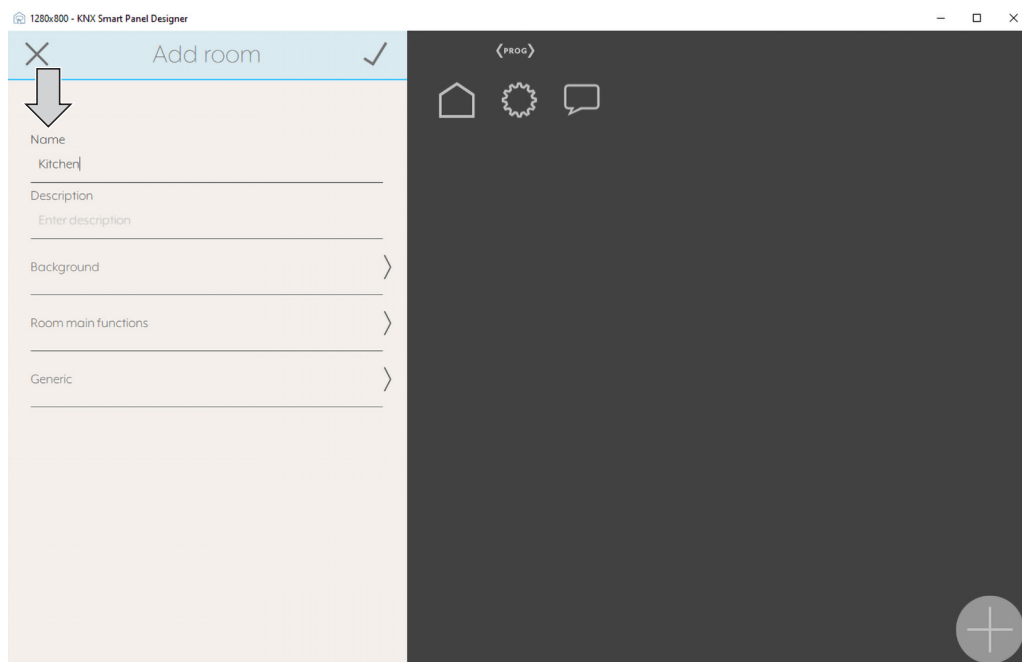

Fig. 18: Smart Panel Designer – “Add room” menu

- Enter the name for the room.
- Optionally, select a background image.
- Show or hide central functions as an option.
- Optionally, configure authorisations and visibility in the “General” submenu.
- Confirm the configuration with a checkmark.
The newly added room is displayed in the room overview.

6.1.5 Creating and configuring elements

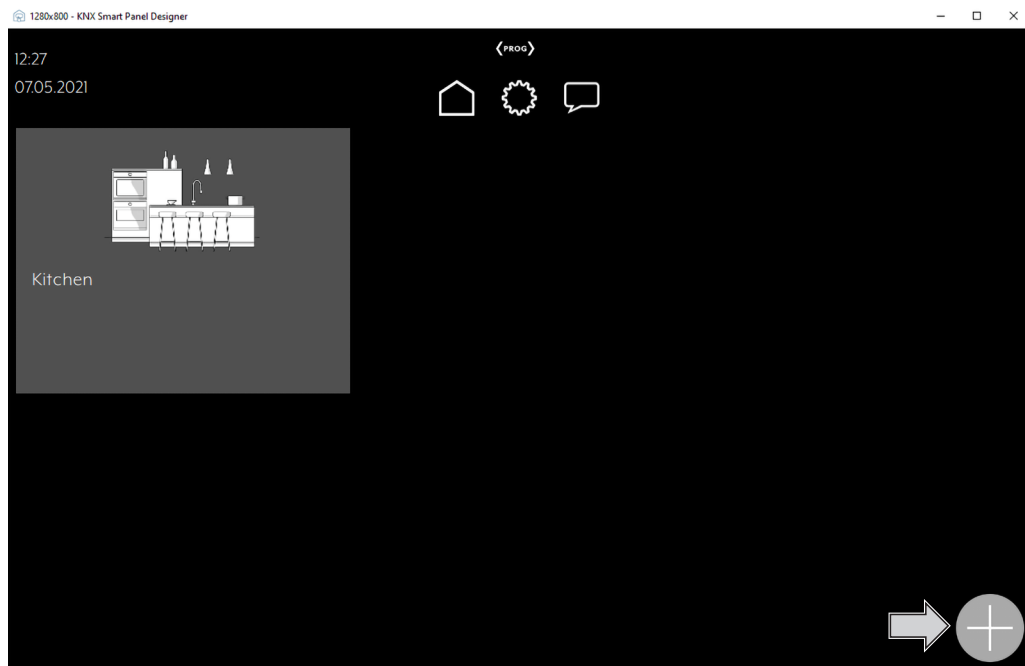

Fig. 19: Smart Panel Designer – Creating and configuring elements

Preconditions:

User is logged in as an Administrator.

Configuration mode is activated.

- Add a new element using the Plus icon.
The “Add element” menu is displayed.

“Add element” menu

- Parameters:

Under “Parameters”, additional setting options are available, depending on the element type. For certain elements, icons, for example, can be taken from the internal library for further personalisation. In addition, some elements possess individual setting options with regard to operation and KNX functionality.

- Authorisations:

If necessary, an element can be given different access rights. The access rights of different users can be individualised for an element under “Add element → General”.

Description see page 44

- Visibility:

Description see page 28

- Block:

Description see page 29

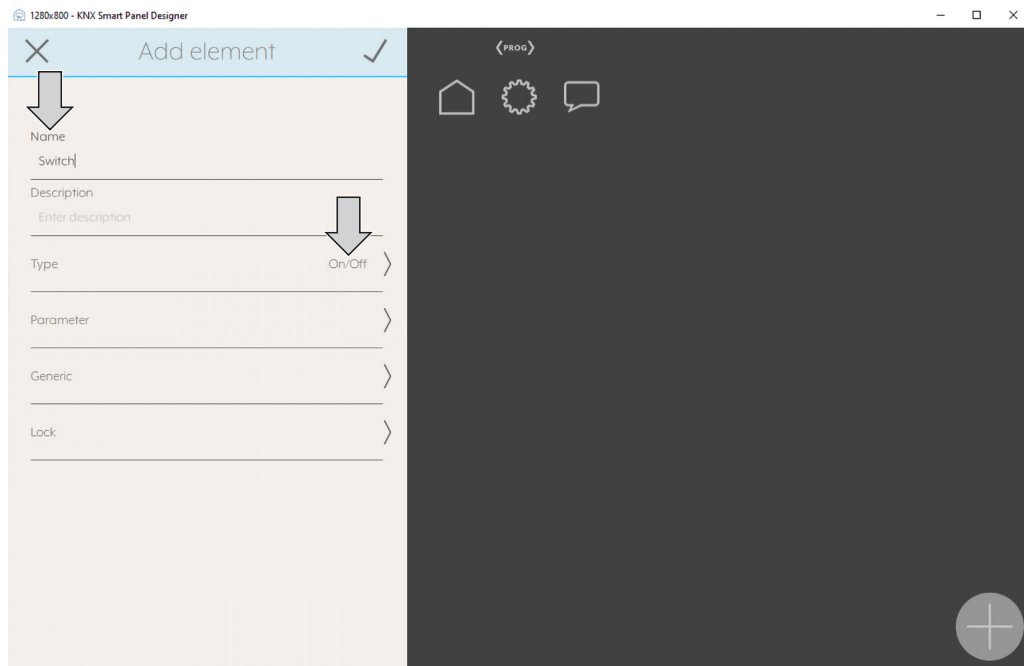

Fig. 20: Smart Panel Designer – “Add element” menu

- Enter the name for the element.
- Select the type of element.
Additional configuration options become visible, depending on the type of the element.
The following sections shows the options for the On/Off type (e.g. switch) by way of an example.
- Optionally, configure parameters.
- Optionally, configure authorisations, visibility and additional functions in the “General” submenu.
- Optionally, configure blocks.
Description see page 29
- Confirm the configuration with a checkmark.
The newly added element is displayed in the room view.

Hide element

If necessary, an element can be switched to be visible/invisible. The element is then only visible within the project design software and is shown transparently. This does not apply for later depiction on the display. However, this means that there is no need to create the element again. It is hidden when shown on the display.

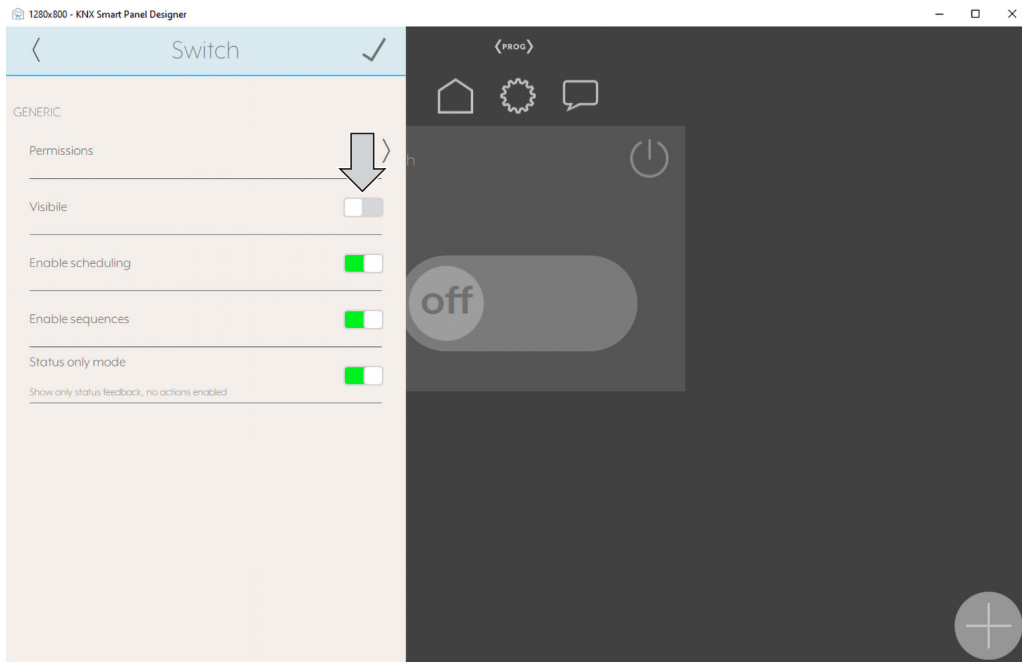

Fig. 21: Smart Panel Designer – Hide element

- Select the “General” menu in the settings of the appropriate element.
- Deactivate visibility with the toggle.
- Confirm the settings with a checkmark.
Settings for visibility are applied.
The element is displayed semi-transparently.

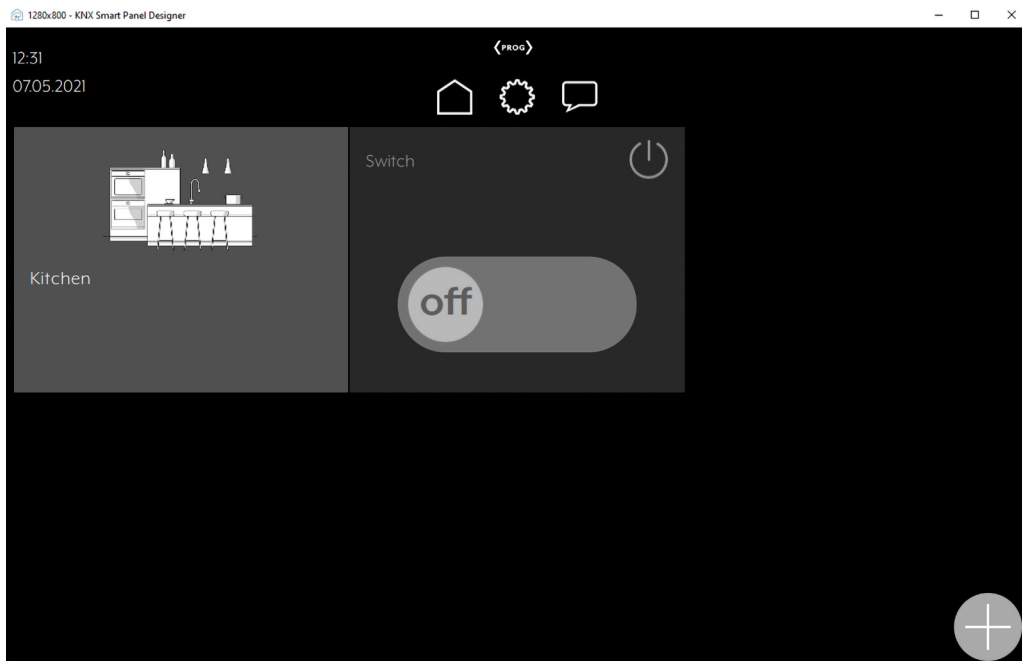

Fig. 22: Smart Panel Designer – Invisible element

Blocking an element

The “Activate block” option generates a communication object for later linking within the ETS. The 1-bit object can be used to block and unblock the element on the user interface (enable). If necessary, the value for “Blocked/unblocked” can be inverted and the behaviour of the element on blocking (no action/on/off) can be set. A blocked element can be seen on the Smart Panel in the overlay with a lock symbol.

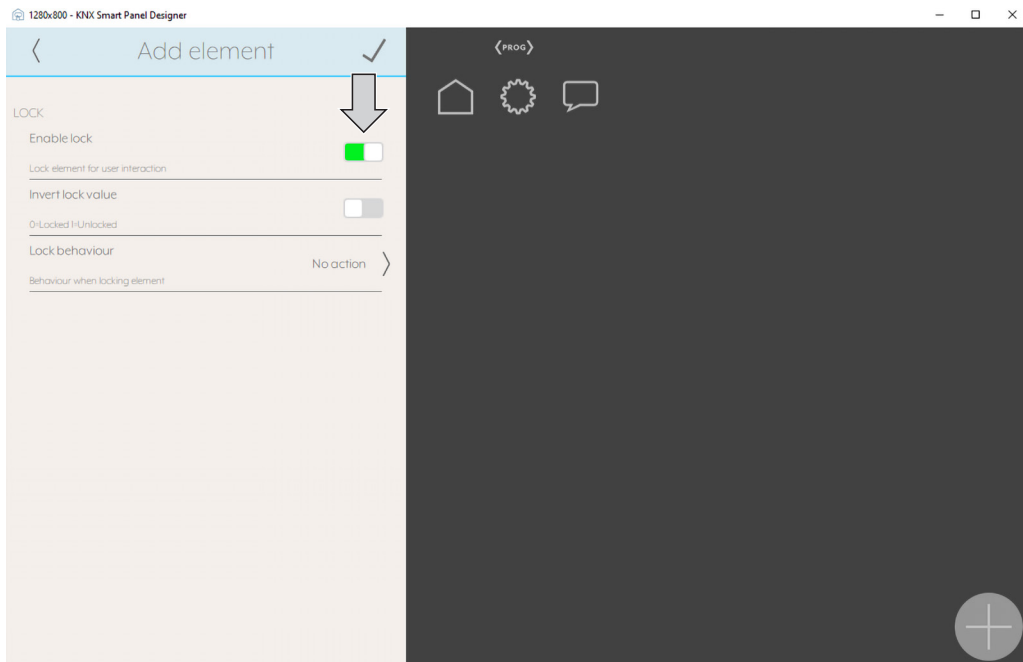

Fig. 23: Smart Panel Designer – Block element

- In the “Add element” menu, activate the block of the appropriate element using the toggle switch.
- Optionally, invert the value block.
- Optionally, configure the behaviour on a block.
- Confirm the settings with a checkmark.
Settings for the block are applied.

The element is displayed in JUNG Smart Vision with a lock icon.

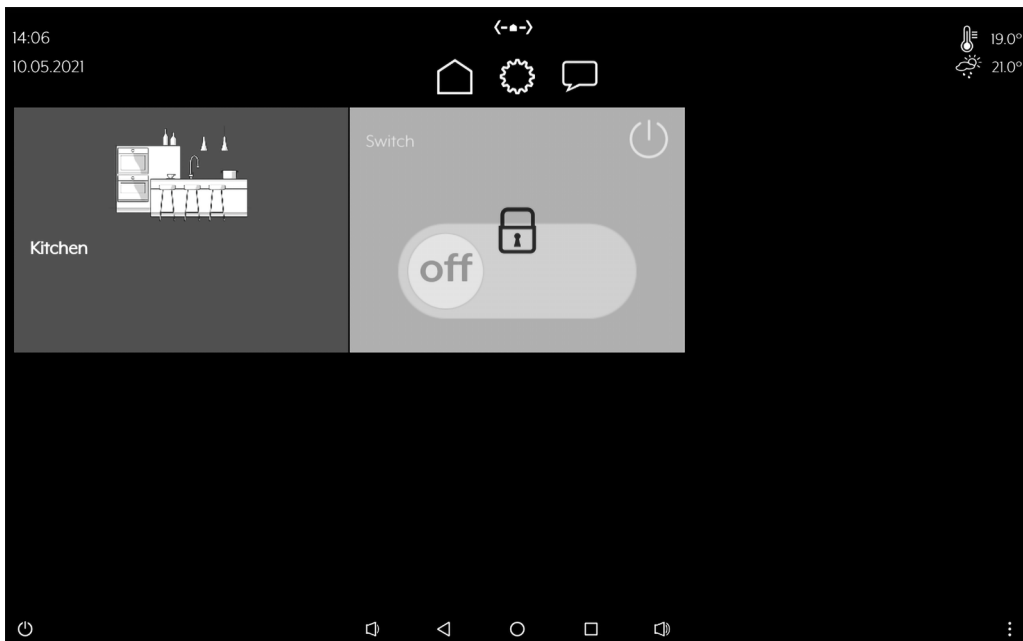

Fig. 24: JUNG Smart Vision – Blocked element

Editing, copying or deleting rooms/elements

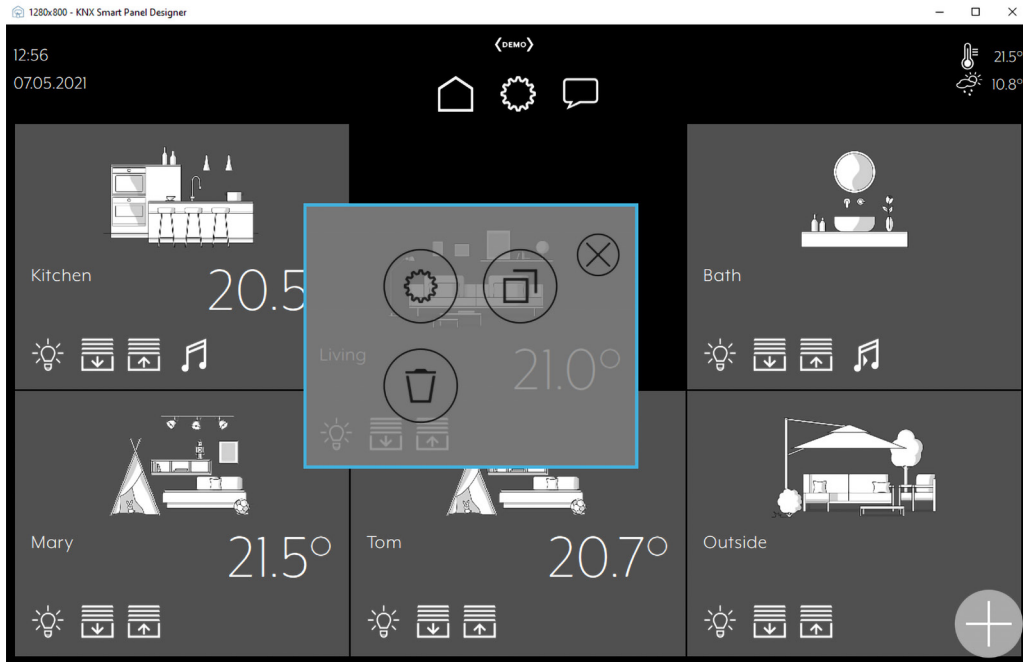





Fig. 25: Smart Panel Designer – Changing, copying or deleting rooms/elements

- Select the room/element with a long press of the left mouse-button or clicking the right mouse-button. Icons for editing are displayed.
- Edit, copy, delete or move the room/element.
To move it, hold the left mouse button down at the edge of the room / element until the edge becomes coloured.

Icon	Name	Explanation
	Change	Change room/element
	Copy	Copy room/element
	Delete	Delete room/element
	Cancel edit	Editing is cancelled, icons are hidden

6.1.6 Configure time planning for an element

Preconditions:

User is logged in as an Administrator.

Configuration mode is activated.

Activate time planning

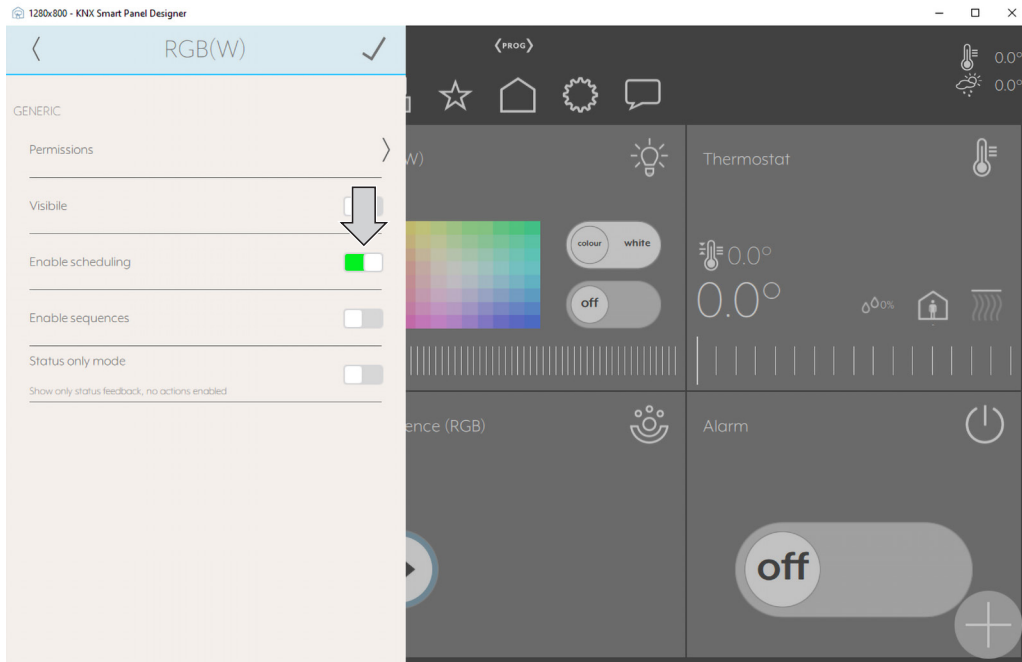

Fig. 26: Smart Panel Designer – Activate time planning

- Select the “General” menu in the settings of the appropriate element.
- Activate time planning with the toggle switch.
- Confirm the settings with a checkmark.
Settings for time planning are applied.

Create time planning

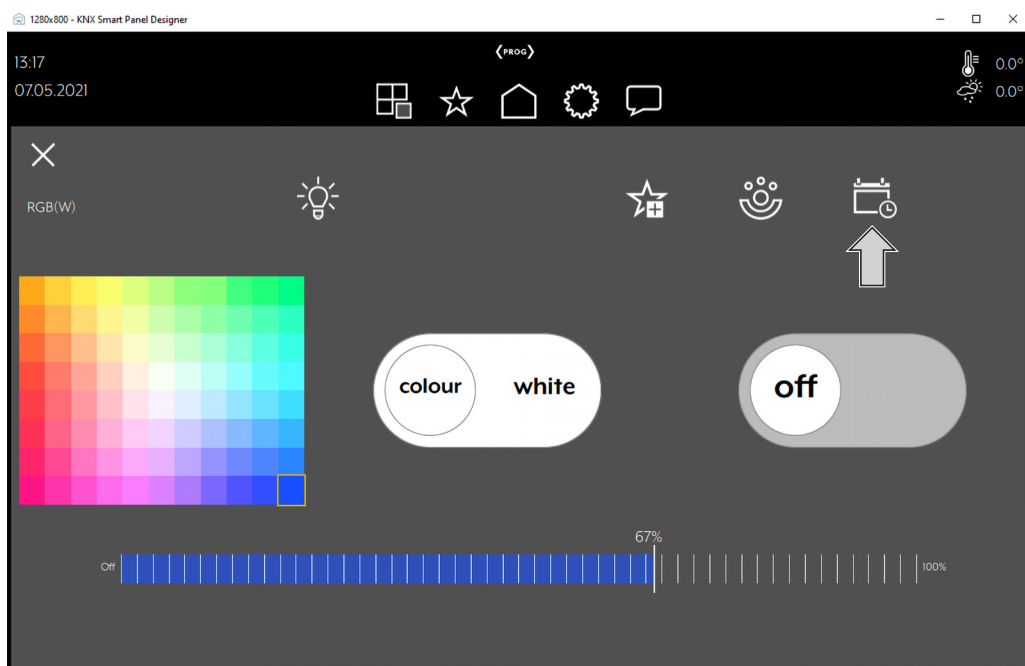

Fig. 27: Smart Panel Designer – Create time planning

- Display detailed view of the element.
- Select the time planning icon.
“Time planning: Overview” is displayed.

Add a task to the time planning

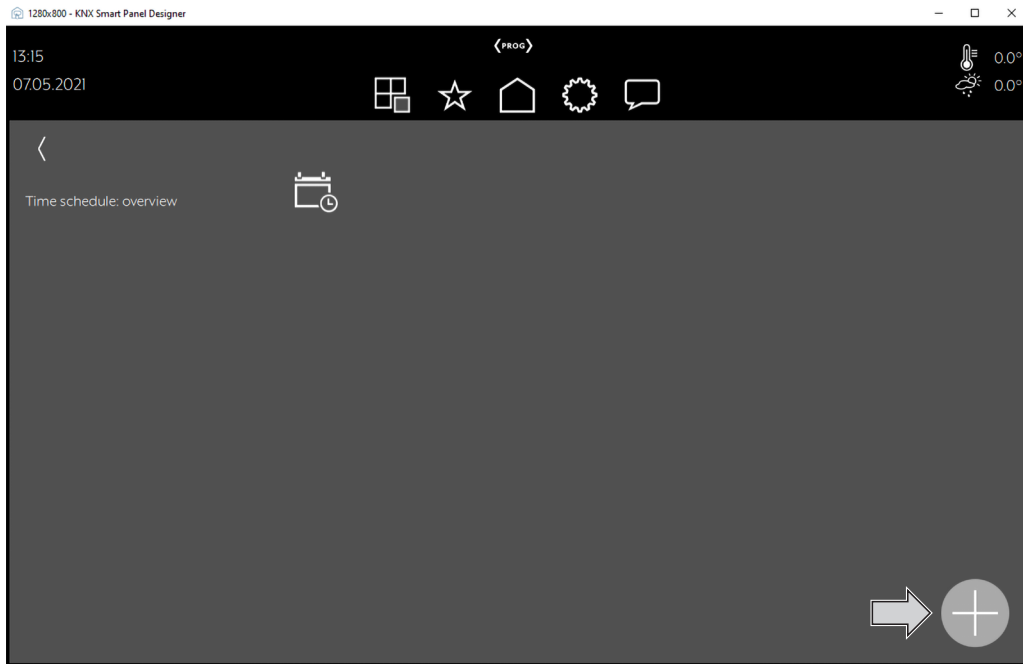

Fig. 28: Smart Panel Designer – Add a task to the time planning

- Add time planning to the element using the Plus icon.
“Time planning: Task list” is displayed.

Create a task for time planning

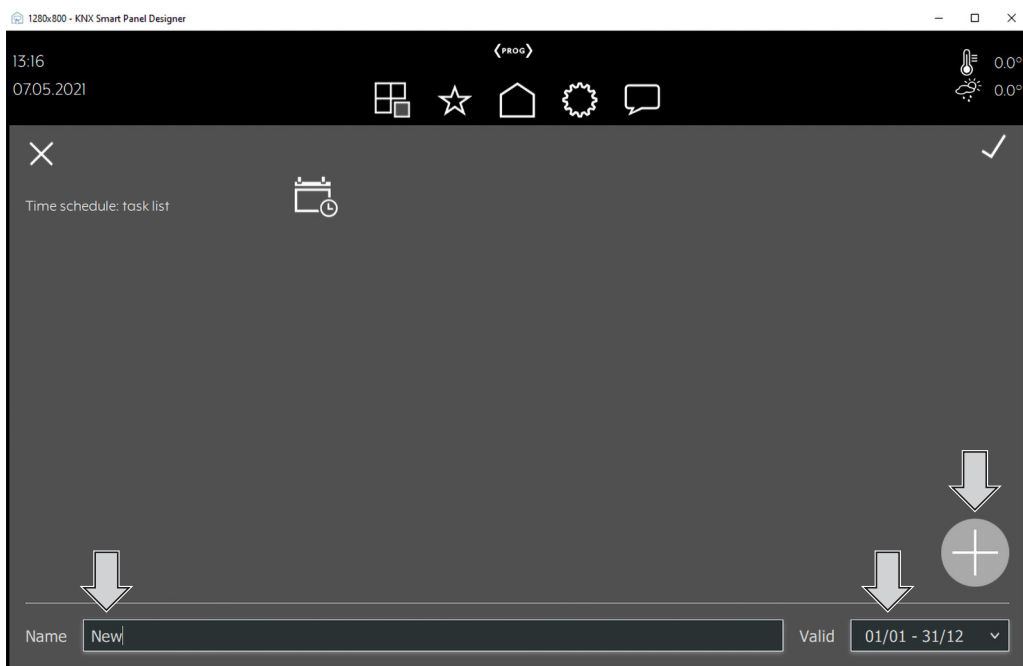

Fig. 29: Smart Panel Designer – Create task for time planning

- Enter a name for the task and select a time period for the validity.
- Add a task to the time planning using the Plus icon.
“Time program: Details” is displayed.

Select a time point for task execution

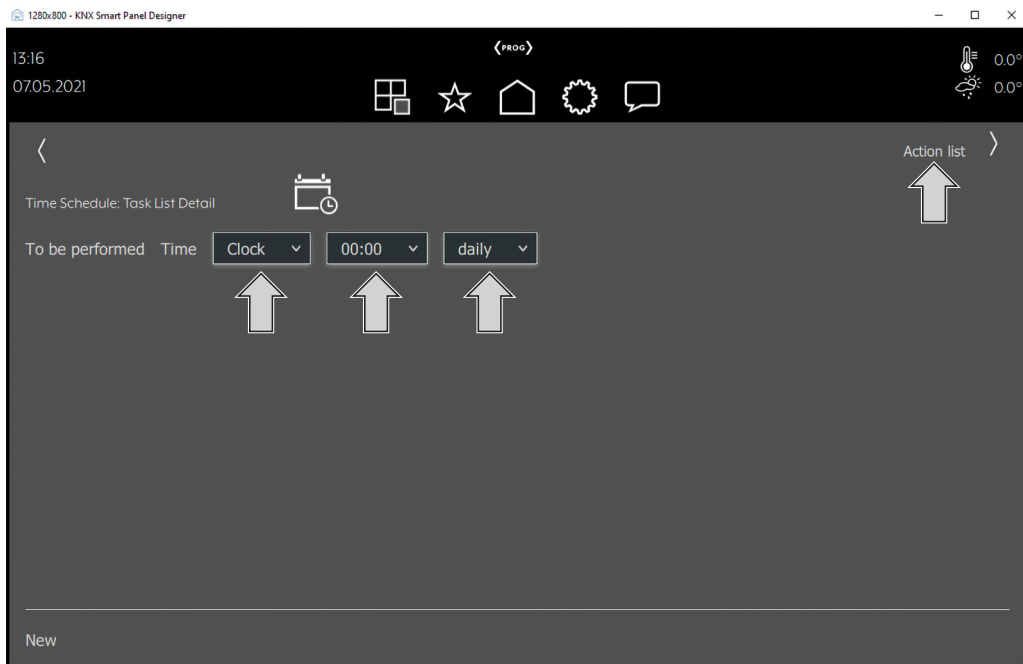

Fig. 30: Smart Panel Designer – Select a time point for task execution

- Select a time point for task execution.
To do this, either select the time and repeats or select sunrise/sunset.
i Sunrise/sunset is only available if the astronomical clock was activated.
Description see page 48
- Select the action list.
“Time planning: Action list” is displayed.

Add an action to the time planning

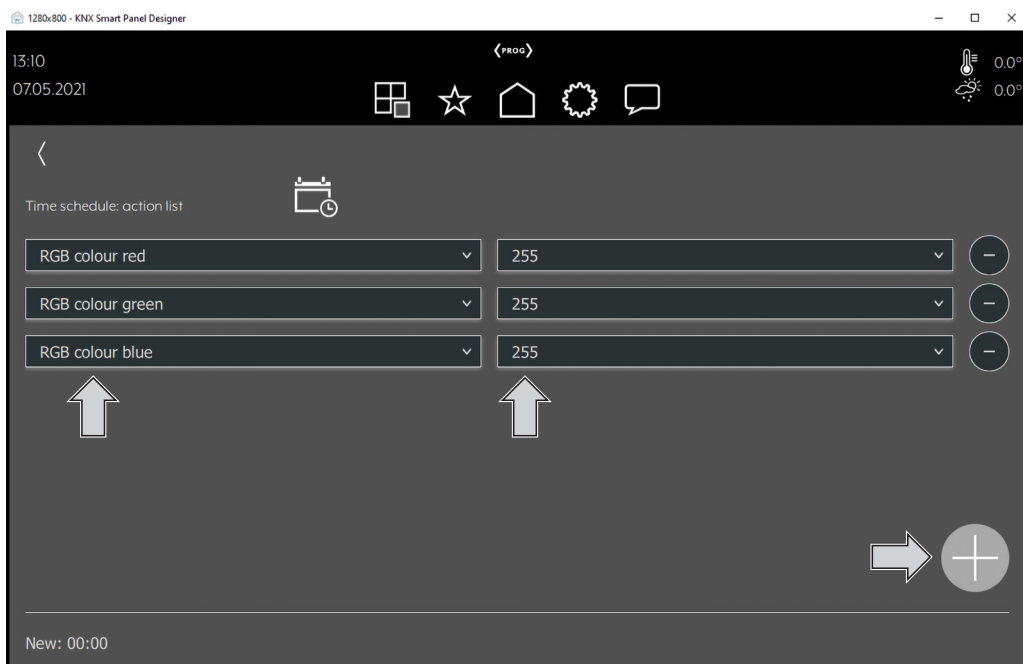

Fig. 31: Smart Panel Designer – Add an action to the time planning

- Add an action for time planning to the element using the Plus icon.
The action is added to the action list.
The new time planning is displayed in “Time planning: Overview”.
Optionally, configure element-specific functions of the action.

Editing, deactivating or deleting the time planning

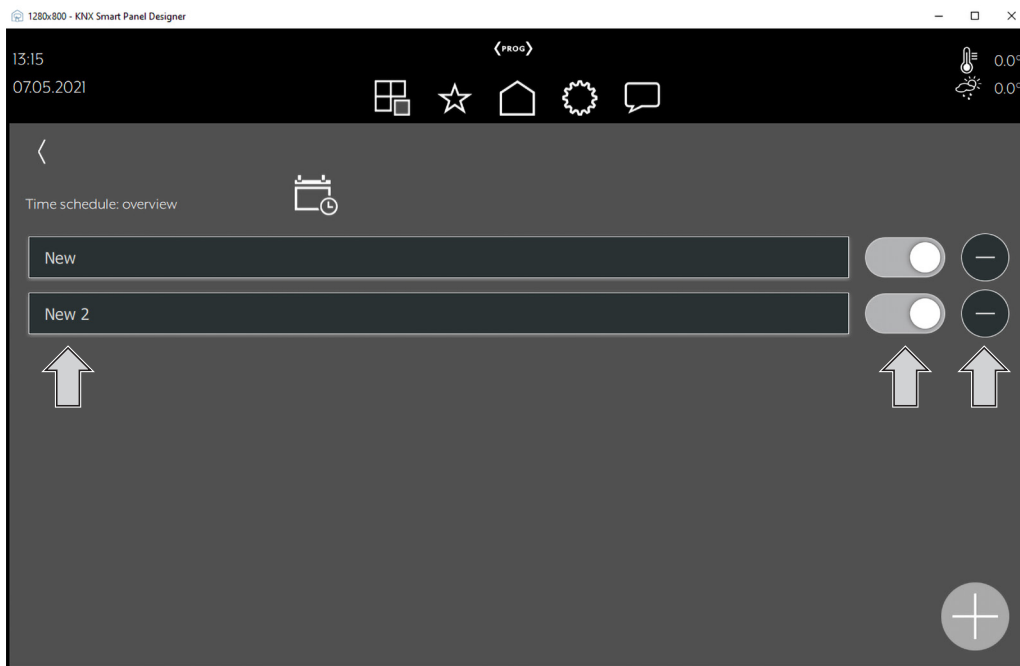

Fig. 32: Smart Panel Designer – Editing, deactivating or deleting the time planning

- Select the time planning to be edited directly, deactivate it with the toggle switch or delete it using the Minus icon.

6.1.7 Configure sequences for an element

Preconditions:

User is logged in as an Administrator.

Configuration mode is activated.

Activating a sequence for an element

In generally, only those elements can be included in sequences that were previously activated for it. Activation takes place in the “General” menu in the appropriate element.

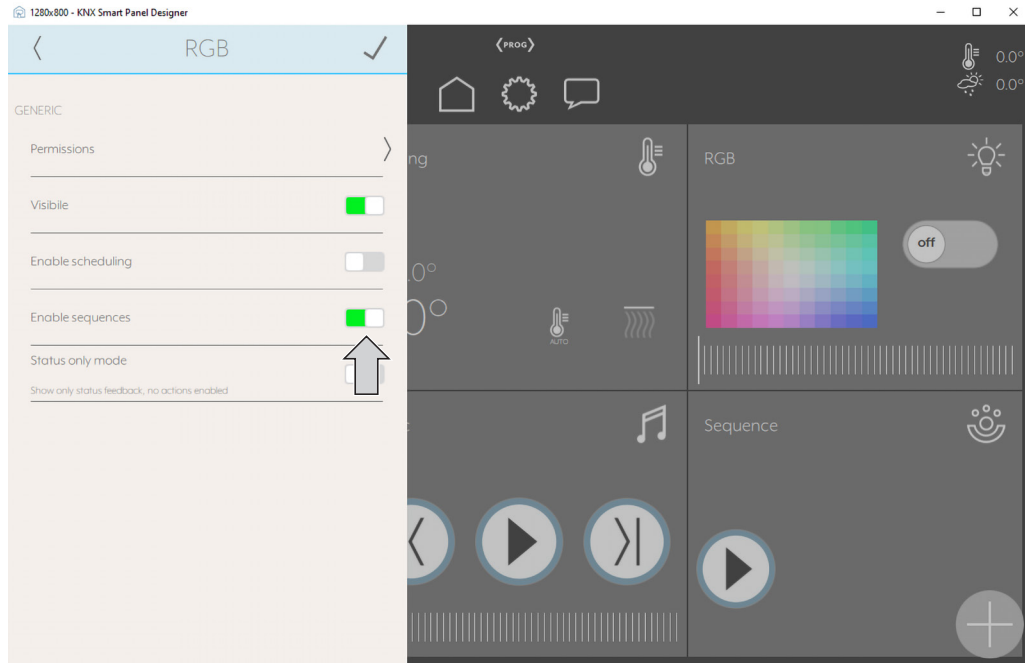

Fig. 33: Smart Panel Designer – Activating a sequence for an element

- Select the “General” menu in the settings of the appropriate element.
- Activate sequences with the toggle switch.
- Confirm the settings with a checkmark.
Settings for the sequences are applied.

Creating a sequence

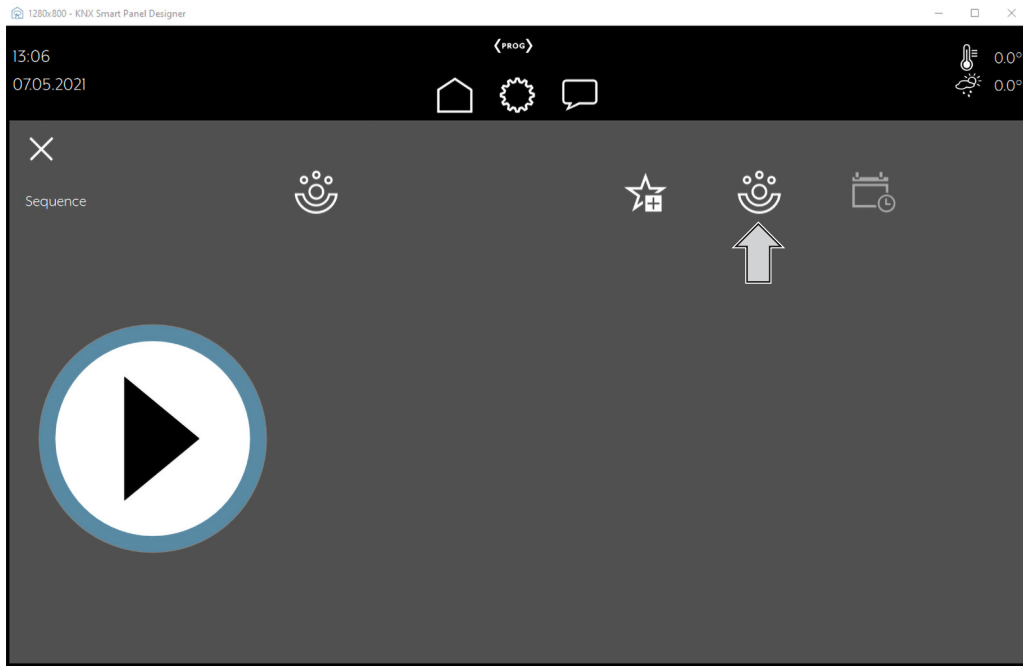

Fig. 34: Smart Panel Designer – Create sequence

- In the room view of the appropriate room, add a new element of type “Sequence” with the Plus icon.
- Display detailed view of the new element.
- Select the sequence icon.
“Configure sequence” is displayed.

Configuring a sequence

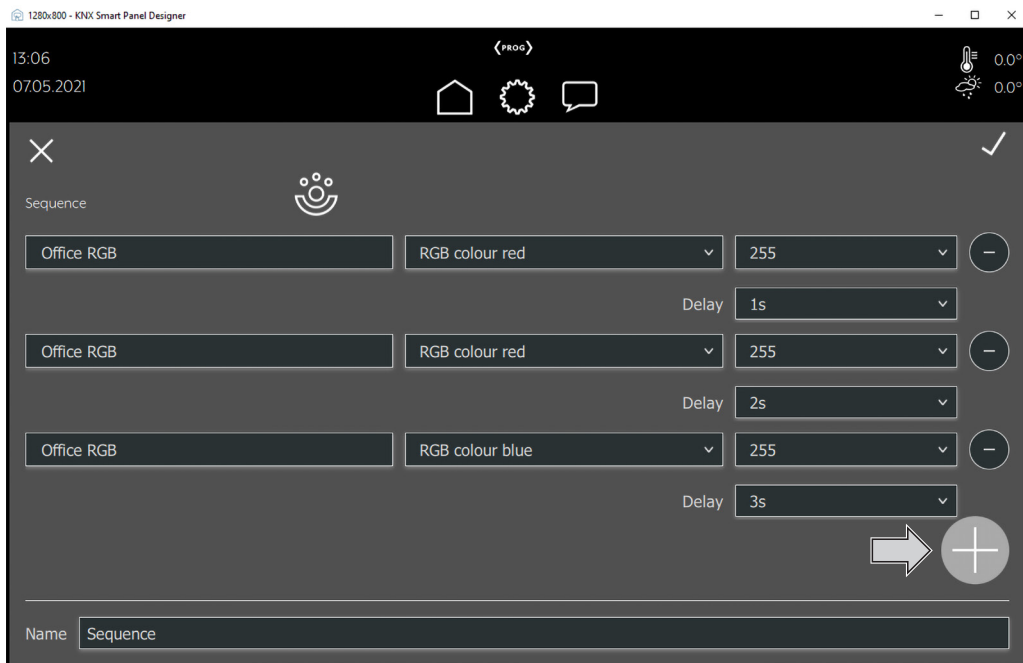

Fig. 35: Smart Panel Designer – Configure sequence

- Add elements to the sequence with the Plus icon.
The elements must be activated for sequences.
Description see page 35
- Optionally, configure a delay and further settings of the elements.
- Confirm the settings with a checkmark.
Settings for the sequence are applied.

6.1.8 Configure advanced settings

In addition to the design of the user interface, additional options can be found under “Settings” for special functions, logic operations, messages, time plans and user management. These setting options are explained in the following subchapters.

Preconditions:

User is logged in as an Administrator.

Configuration mode is activated.

Overview of the menu structure

- Configuration
 - Visualisation
 - Design
 - Logic operations
 - Messages
 - User management
 - Users
 - User management
 - Plugins
 - Astronomical clock
 - Synchronise date/time
 - Presence simulation
 - Sequence button
 - Export/Import
 - Export
 - Import
 - Reset
- App
 - Language
 - Design
 - Log
 - Log Level
 - Demo mode
 - Software update information

“Design” submenu

Settings → Configuration → Visualisation → Design

Date and time:

The date and time can be shown or hidden within the top status and navigation bar using the “Design” menu item. Both are shown as standard. The temperature values for the indoor and outdoor temperature can also be activated/deactivated. For each, a communication object is created in the project file for later linking within the ETS, provided that the display was activated.

Single room mode:

Activating/deactivating Single room mode dissolves the room structure and all the rooms and/or functions are combined in one room. Single room mode is deactivated as standard.

IMPORTANT:

After Single room mode is activated, the created central functions disappear!

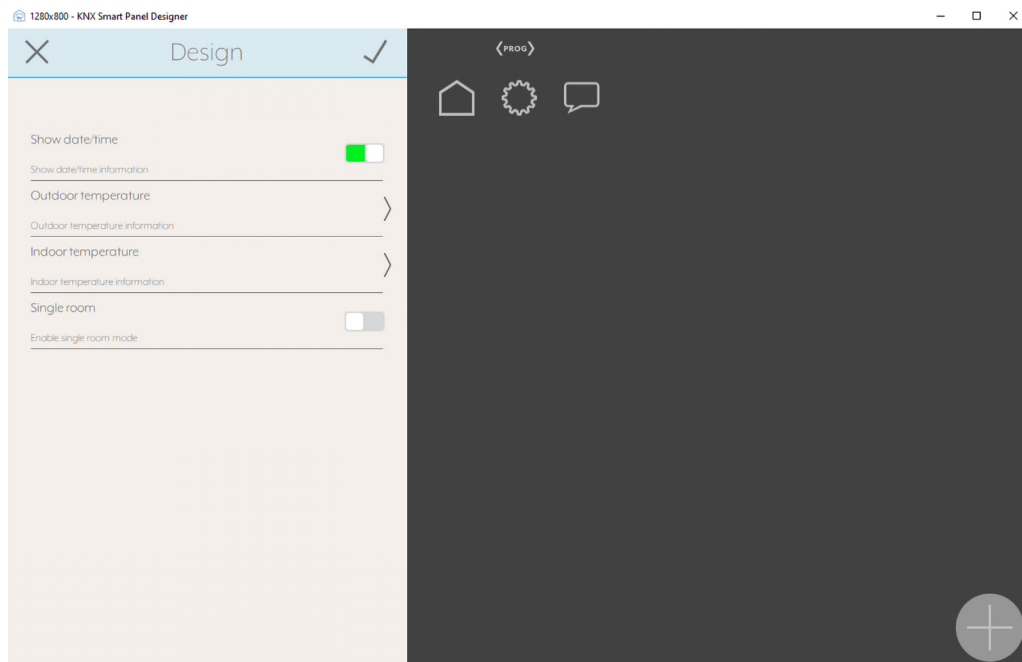

Fig. 36: Smart Panel Designer – “Design” submenu

The following settings can be made:

- Show date/time display
- Outdoor temperature
- Indoor temperature
- Single room
- Confirm the settings with a checkmark.
Settings for the design are applied.

“Logic operations” submenu

Settings → Configuration → Logic operations

The KNX Smart Panel Designer possesses an internal logical editor, using which “If-Then-Else” instructions can be implemented for the JUNG Smart Vision app and later loaded into the device. New logic operations can be created using the plus icon. Existing logic operations can be searched for and edited using the magnifying glass icon.

Additional triggers (“If”) can be added using the small plus icon. Logic operations can be deleted again through a long press or by right-clicking the name within the list view.

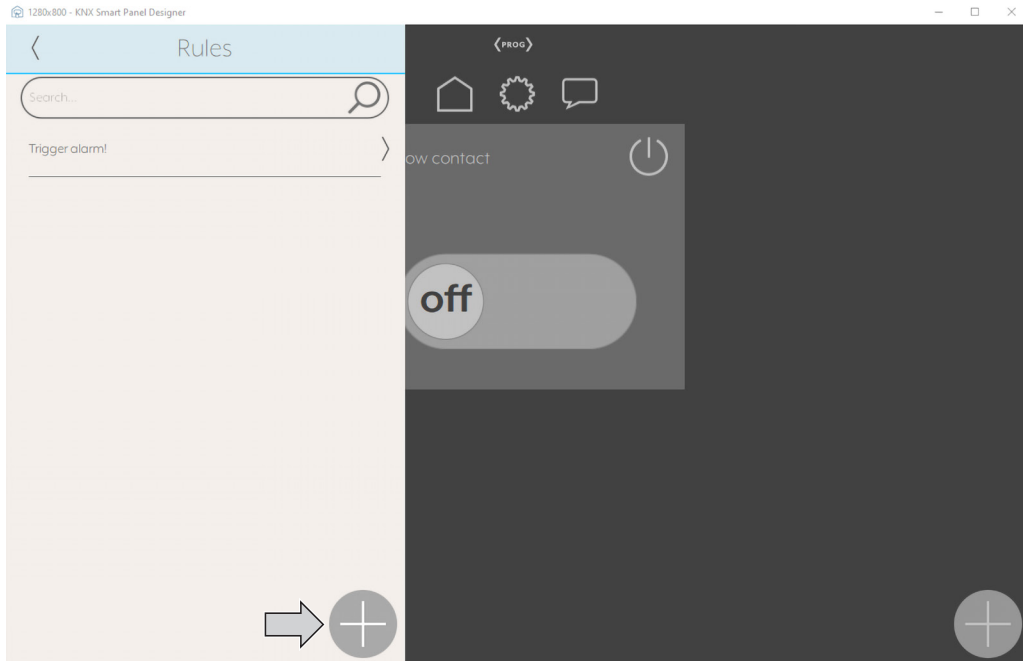

Fig. 37: Smart Panel Designer – “Logic operations” submenu

- Add a new logic operation using the Plus icon.
The “New logic operation” submenu is displayed.

“New logic operation” submenu

Settings → Configuration → Logic operations → New logic operation

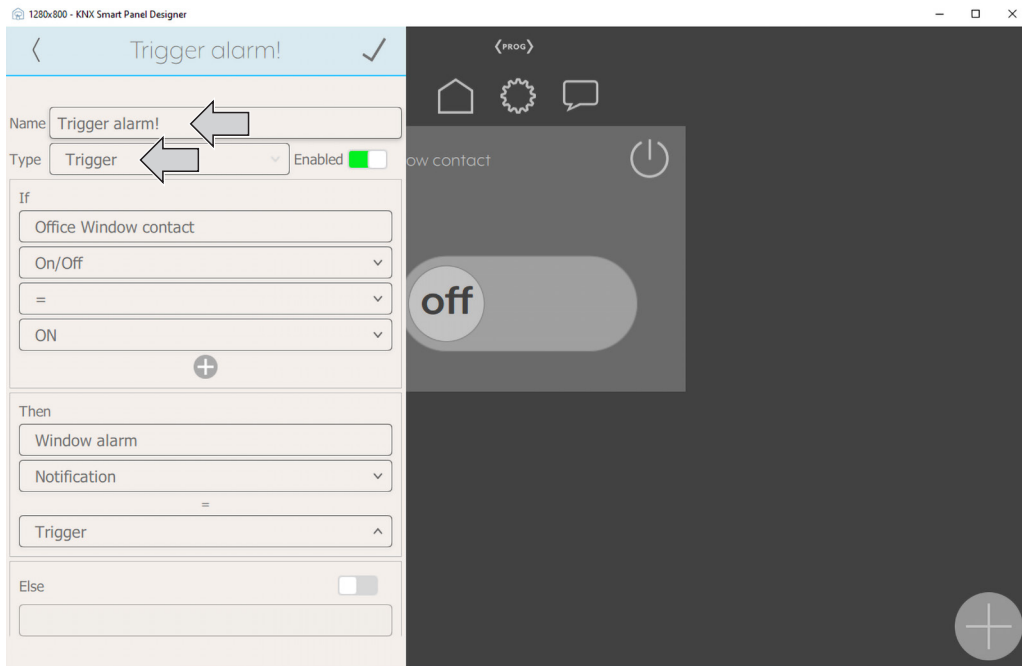

Fig. 38: Smart Panel Designer – “New logic operation” submenu

- Enter the name for the logic operation.
- Select the type of logic operation.
- Define the “If-Then-Else” instructions for the logic operation.
- Add optional “AND”/“OR” instructions using the small plus icon.
- Confirm the settings with a checkmark.
Settings for the logic operations are applied.

Logic operation types

Type	Explanation
As required	Logic operation is activated, e.g. through time planning.
Trigger	Logic operation is evaluated on each new telegram in conjunction with a used data point.
On a value change	Logic operation is only evaluated when the value of a used data point has changed effectively.

“Messages” submenu

Settings → Configuration → Messages

The software allows the creation and output of messages on the device. Messages can be (globally) activated/deactivated in the “Messages” menu. Individual messages are created using the plus icon. Existing messages can be searched for and edited using the magnifying glass icon.

Messages can be deleted again through a long press or by right-clicking the name within the list view. Each message can be given an additional message using the text box. In addition, a pop-up on the display and a signal tone can be output.

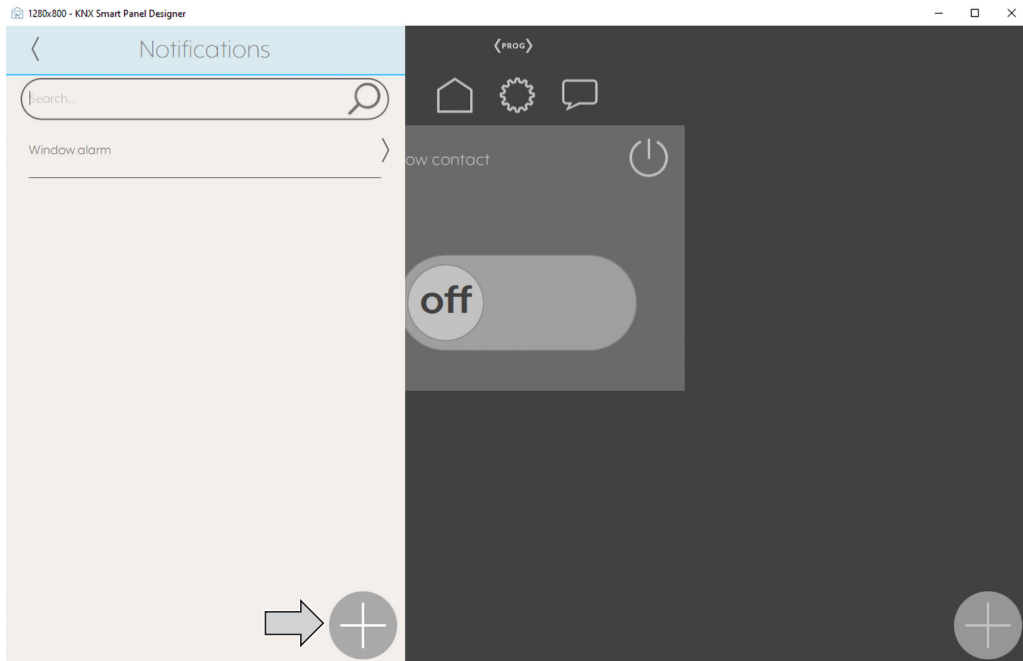

Fig. 39: Smart Panel Designer – “Messages” submenu

- Add new messages using the plus icon.
The “New messages” submenu is displayed.

“New messages” submenu

Settings → Configuration → Messages → New messages

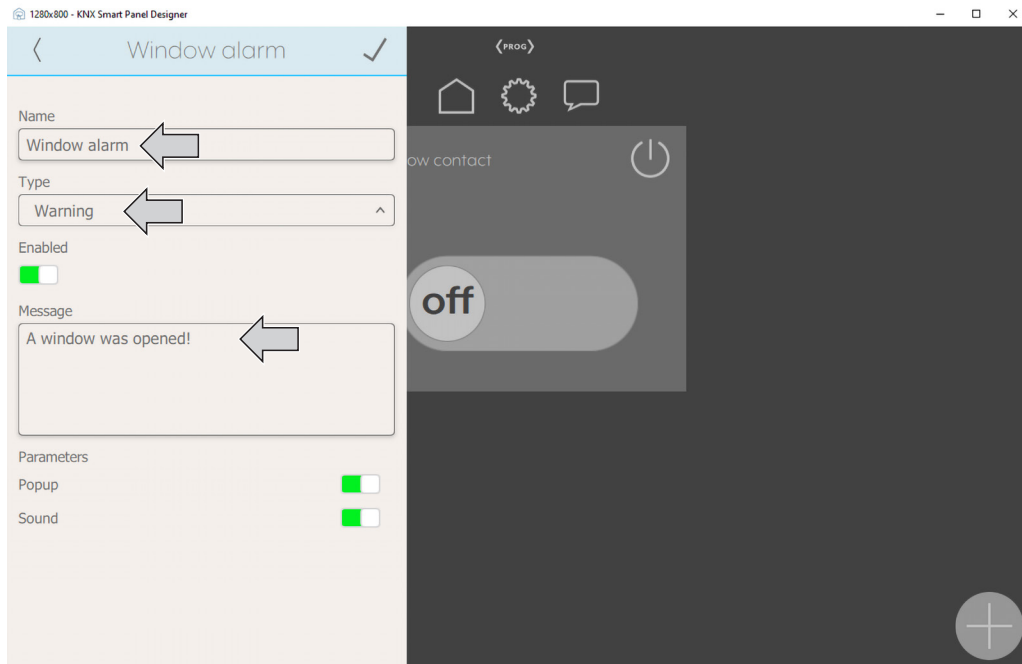

Fig. 40: Smart Panel Designer – “New messages” submenu

- Enter the name for the message.
- Select the type of message.
- Enter the message.
- Optionally, activate the pop-up and acoustic signalling parameters.
- Confirm the settings with a checkmark.
Settings for the messages are applied.

Message types

The types Info, Warning and Alarm stand for the corresponding levels of importance in ascending order. Each value is linked to a different acoustic signal tone, which can be played back as required. Messages can be integrated into logic operations.

Type	Explanation
Info	Lowest level
Warning	Medium level
Alarm	Highest level

General information on messages

In general, there are two types of message:

- System-wide messages, with which the system provides warnings or suggestions. These messages are generated independently by the system and are also generated when the messages in the menu are deactivated.
- Messages on the User level, which appear during user-defined events. This type of messaging can be activated or deactivated via the menu. In consequence, the icon in the top bar is also shown or hidden.

Messaging on the User level can be combined with a signal tone and output using a pop-up window. The message then appears are triggering in the message window in the JUNG Smart Vision app.

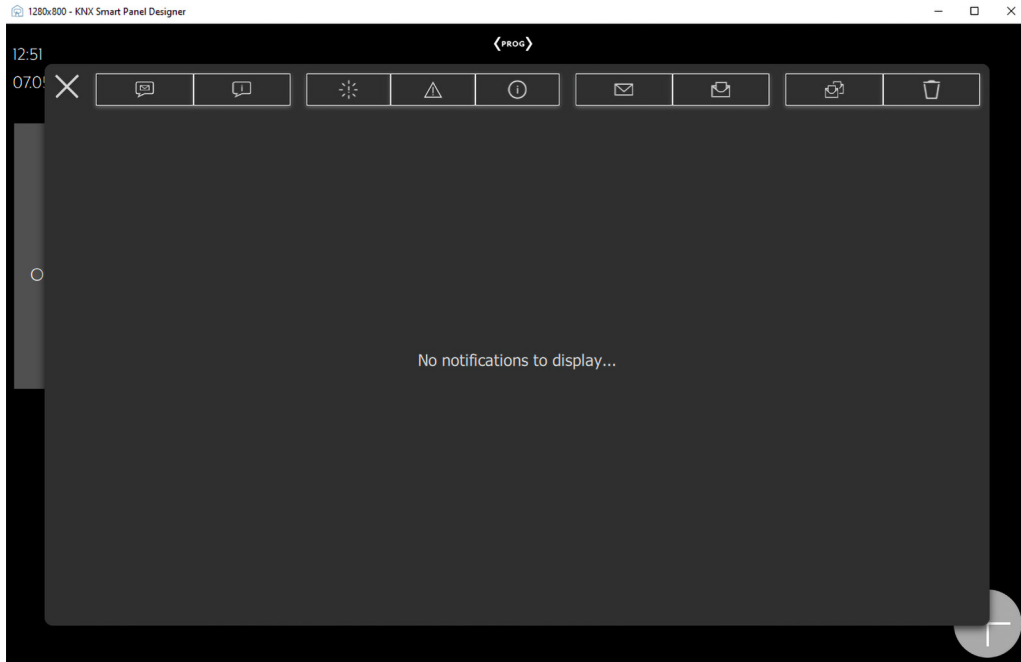

Fig. 41: Smart Panel Designer – Message window

“User management” submenu

Settings → Configuration → User management

As standard, there are two access levels within the software. On the one hand, there is the Administrator level with the standard PIN code 74269, and also the User level, which can operate the visualisation without PIN entry.

All user access with a PIN code is terminated automatically after a standard timeout of 15 minutes. The work session times out after 15 minutes without an interaction with the device or software. The cog symbol in the top centre of the screen becomes transparent again and there is an automatic change to the user level.

Temporary access rights through other users with higher-level rights (e.g. to view contents of a blocked room or to trigger certain functions) are permitted through the PIN entry of the appropriate user. These rights are terminated again after 10 seconds without an interaction (user is logged out).

The rights of the Administrator remain unchanged: They can be neither modified nor deleted. Only the PIN code can and should be changed (min. 5, max. 8 digits).

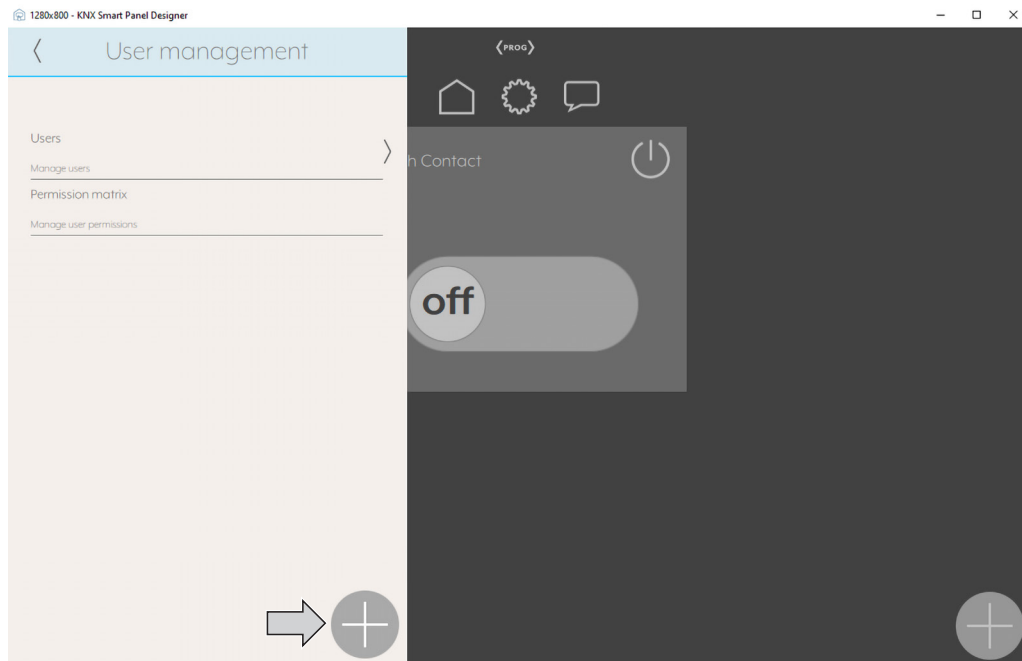

Fig. 42: Smart Panel Designer – “User management” submenu

- Add a new user using the Plus icon.
The “New user” submenu is displayed.

“New user” submenu

Settings → Configuration → User management → New user

All the users are displayed within the list view.

Pressing the plus icon causes the form for a new user to appear. Then, a name can be entered for the user, along with a corresponding PIN code. The PIN code must consist of at least four and at most eight digits.

The corresponding user rights are then selected/deselected under “Authorisations”. User rights can also be set via the authorisation matrix.

All the users then appear in the list view within the user management under “Users” and can be edited and deleted again (with the exception of Administrator/Standard) by a “long press” or “right click” on the name within the list view.

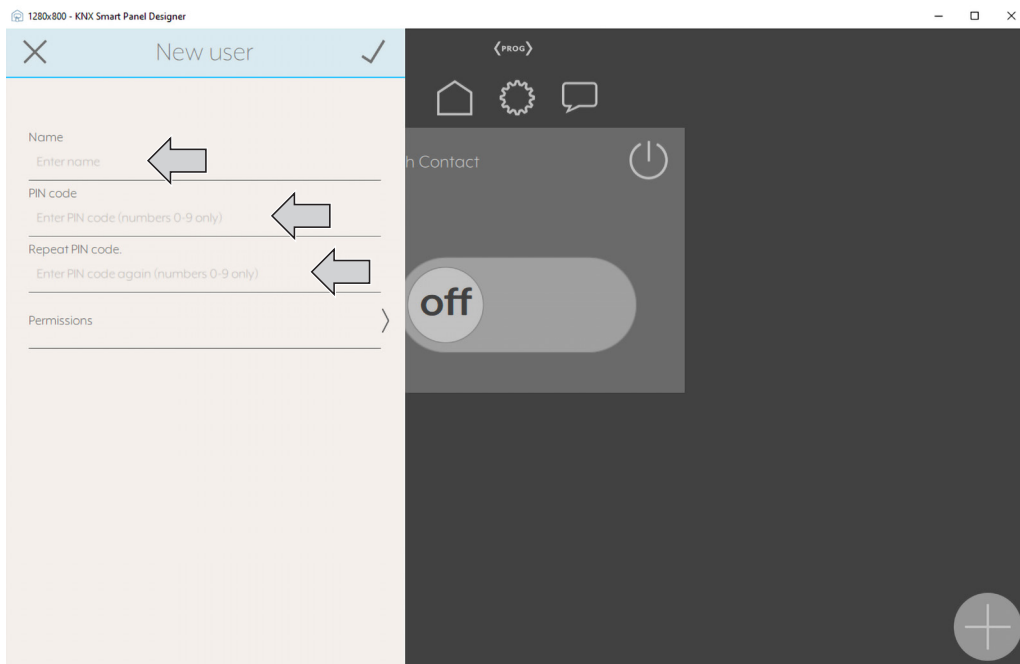

Fig. 43: Smart Panel Designer – “New user” submenu

User rights

The Administrator can define and manage new users through the specification of names, PIN code and appropriate user rights. User rights are determined using an authorisation matrix. The following basic rights are available for configuration:

Type	Explanation
Display	Display rooms and elements with corresponding values
Operation	Operate elements (change values)
Time planning	Manage time planning for elements (add, edit, delete)
Sequences	Manage sequences (add, edit, delete)
Presence simulation	Presence simulation, control playback and recording
User settings	Resort tiles (only KNX Smart Panel Designer) and make additional settings on the Smart Panel, e.g.: Access to App submenu (Smart Panel) Access to Devices submenu (mobile terminals) Access to Couple submenu (Smart Panel)

- Enter the name of the user.
- Enter the PIN code and repeat it.
- Activate or deactivate optional authorisations, such as time planning.
- Confirm the settings with a checkmark.
Settings for the users are applied.

“Authorisation matrix” submenu

Settings → Configuration → User management → Authorisation matrix

Authorisations for individual users can also be configured simply using the authorisation matrix. The desired right can be defined for each additionally created user.

IMPORTANT:

Some of the basic rights have clear dependencies. To operate something (Operation), for example, the user must be able to see it (Display). For this reason, in this example, the “Display” right is shown semi-transparently and cannot be deactivated without deactivating the “Operation” right.



Fig. 44: Smart Panel Designer – “Authorisation matrix” submenu

Notes:

The authorisations “Display” and “User settings” have no dependencies. “Operation” and “Presence simulation” are dependent on the “Display” right. The authorisations must be activated in advance!

The “Time planning” and “Sequences” authorisations are both dependent on the “Operation” authorisation. They can only be activated when the “Operation” and “Display” authorisations are activated beforehand. For this reason, the operation and display rights cannot be denied to a user, to whom “Time planning” and “Sequences” (or both) are assigned.

Colour	Explanation
Green	Assigned authorisation
Red	Denied authorisation
Semi-transparent Green/red	Authorisation cannot currently be changed

- Assign or deny authorisations for users.
- Confirm the settings with a checkmark. Settings for the users are applied.

“Plugins” submenu

Settings → Configuration → Plugins

The “Plugins” menu can be used for optional configuration of additional (KNX) special functions for the visualisation project. Some of these functions impact the KNX Bus directly and, after activation, make additional communication objects available within the ETS

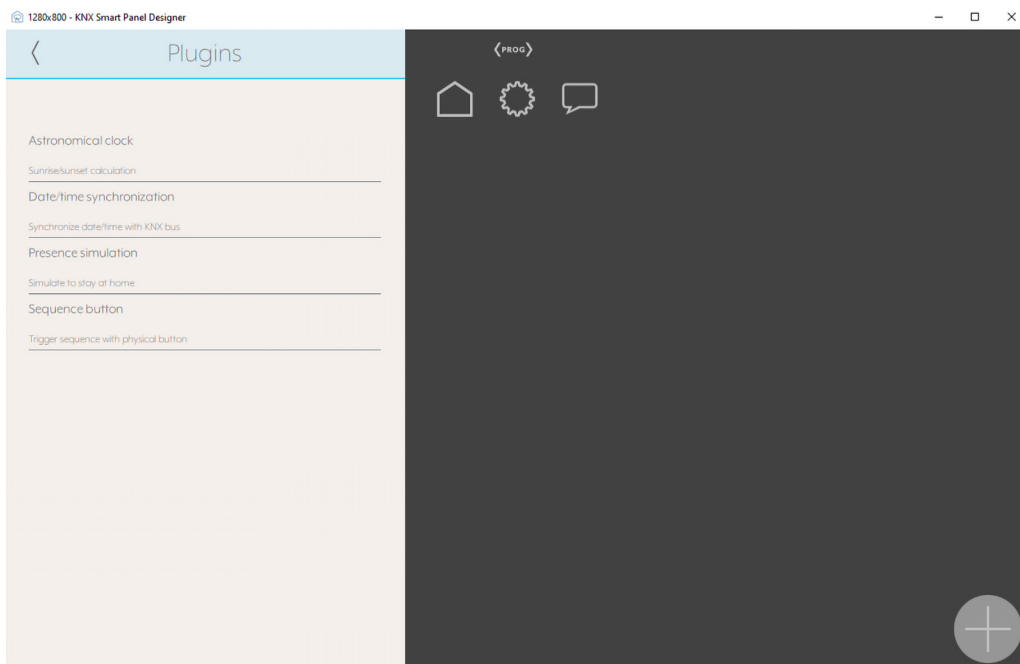

Fig.45: Smart Panel Designer – “Plugins” submenu

“Astronomical clock” submenu

Settings → Configuration → Plugins → Astronomical clock

The astronomical clock can, if necessary, show not just useful information on the display. The data for sunrise and sunset can, for example, be taken into account in time planning as an alternative to fixed times.

The geographic data (latitude / longitude) are then entered in the input box. After activation, the function appears as a separate menu item, both in the software and also within the app on the device.

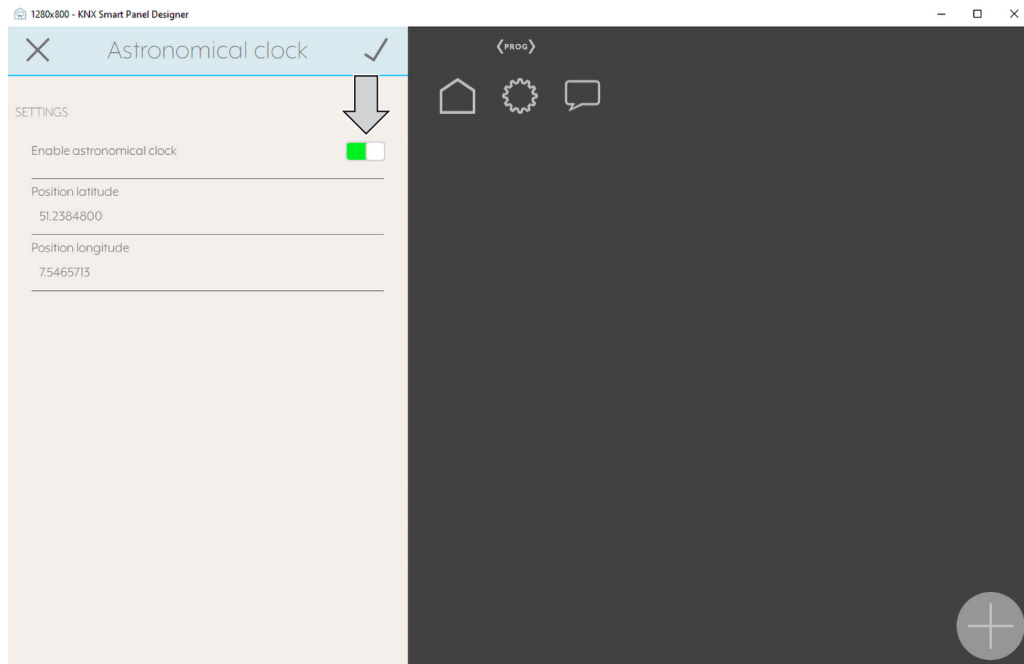

Fig. 46: Smart Panel Designer – “Astronomical clock” submenu

- Activate the astronomical clock with the toggle switch.
- Confirm the settings with a checkmark.
Settings for the astronomical clock are applied.

“Synchronise date/time” submenu

Settings → Configuration → Plugins → Date/time synchronisation

With this function, the current data and time of the device are written to the KNX bus as the date and time data source, as necessary. A local network (LAN) or an external time server is required for reliable outputs.

Alternatively, the synchronisation can also come from the KNX Bus. The Smart Panel or JUNG Smart Vision then obtains the time and date from the bus.

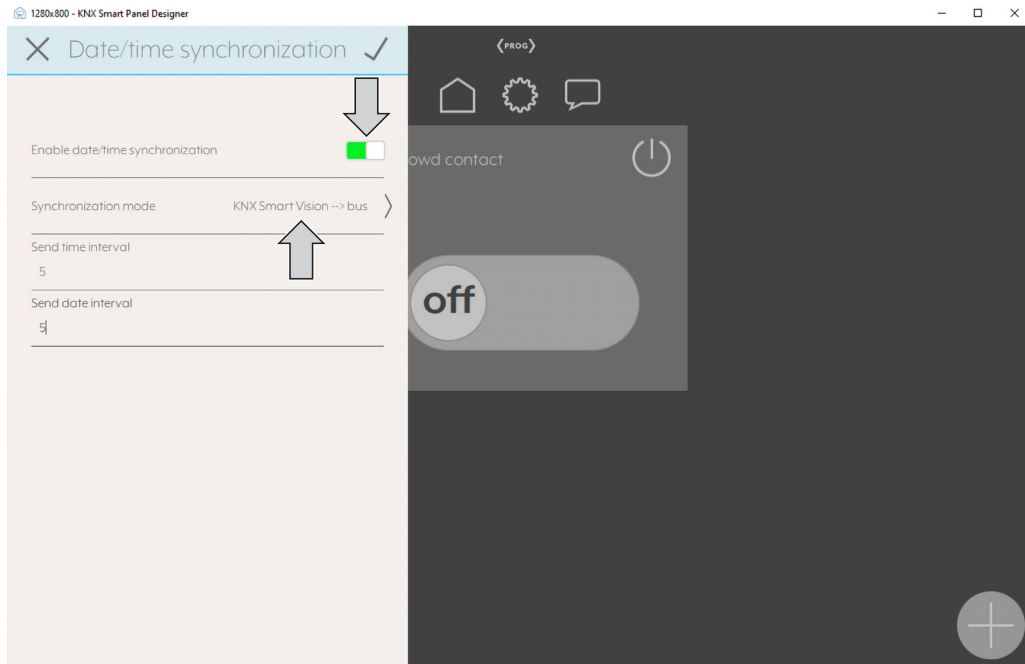

Fig. 47: Smart Panel Designer – “Synchronise date/time” submenu

- Activate Synchronise date/time with the toggle switch.
 - Select Synchronisation mode.
 - As an option, enter the time interval for synchronisation in minutes.
 - As an option, enter the date interval for synchronisation in minutes.
 - Confirm the settings with a checkmark.
- The settings for the Date/time synchronisation are applied.

“Presence simulation” submenu

Settings → Configuration → Plugins → Presence simulation

With the presence simulation, defined data points are recorded within the system during normal use. Recorded actions are then simulated or played back when the user is not at home. The commands transmitted via the KNX Bus are recorded together with a time stamp. If necessary, there is a switch-over to the playback mode of the previous week, in order to simulate presence. In addition, two Start/Stop communication objects and the status of the later link are generated within the ETS.

The following elements can be recorded and played back:

- On/off elements (switch)
- Dimmer
- Blinds
- RGB(W) elements
- Personalised slider

The presence simulation works in two modes:

- Record: Records the defined data in a separate database
- Playback: Playback of recorded data in chronological order

The user can control the switchover between recording and playback themselves. If necessary, using the button provided in the user interface for the running time or based on a KNX data point (communication object).

The binary values are “0” for Record and “1” for Playback (Description see page 93).

IMPORTANT:

The configuration (Playback, Record and Edit) of the presence simulation cannot be performed in the Smart Panel Designer.

Only the preparations for this can be performed in the Smart Panel Designer.

The configuration must be performed in the “Jung Smart Vision” app.

Description see page 66

Activating the presence simulation

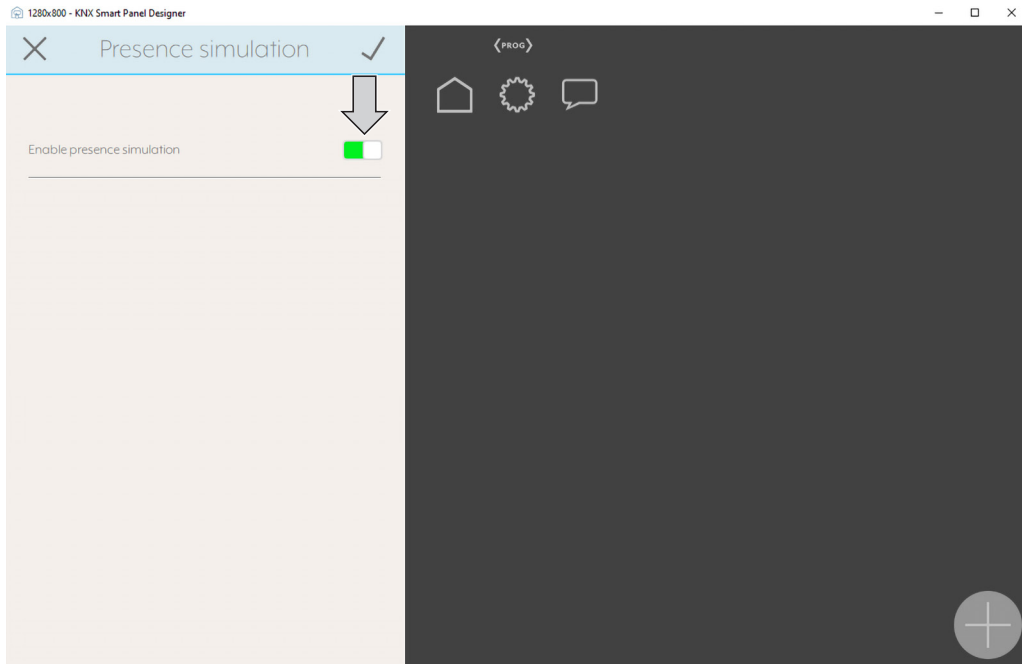

Fig. 48: Smart Panel Designer – Activating the presence simulation

- Activate the presence simulation with the toggle switch.
- Confirm the settings with a checkmark.
 Settings for the presence simulation are applied.
 The “Presence simulation” submenu is displayed in the settings of the appropriate element.

Adding elements to a presence simulation

Functions and elements are connected to or included in the presence simulation singly, in order to be able to change over between recording and playback later on. For this, each individual element or each function, which is to belong to the presence simulation, must be explicitly activated/deactivated. As soon as the plug-in for the presence simulation has been activated, a corresponding entry on the presence simulation appears in each element.

Then, in the “Presence simulation” submenu, it is possible to define within the element which function is to be taken into account during recording/playback. The entries appear in element-specific form in a list.

After the selection of the appropriate function, it is necessary to configure whether the function is recorded and/or played back during operation.

As soon as the selected elements have all been selected and configured, the settings made are automatically transferred to the project file (*.ksp) for later ETS programming.

“Presence simulation” submenu

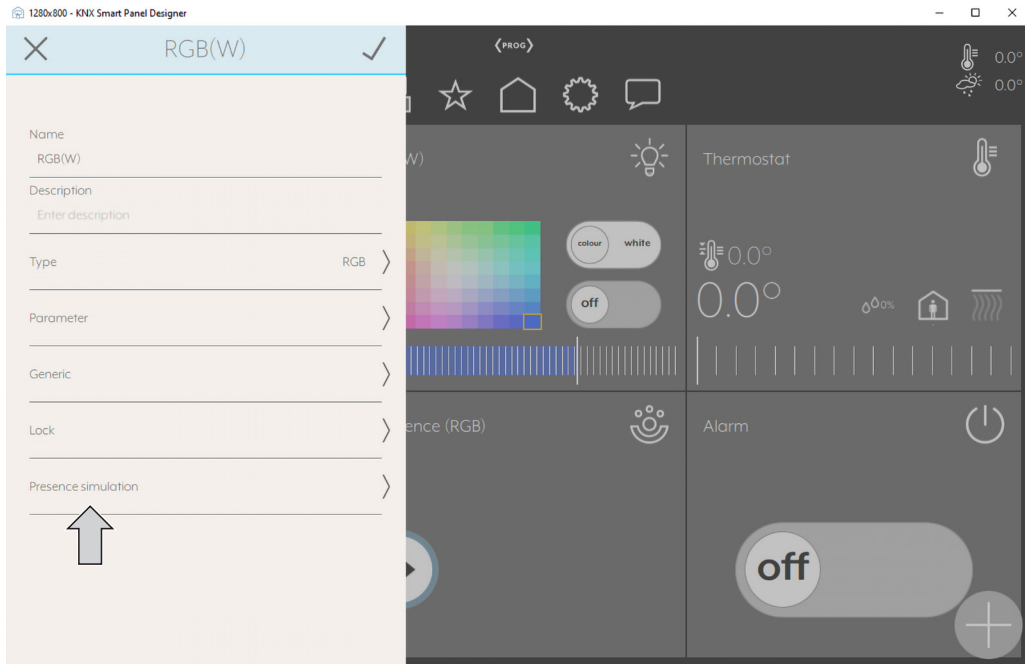

Fig. 49: Smart Panel Designer – Adding elements to a presence simulation

- Select the “Presence simulation” submenu in the settings of the appropriate element. The list of elements for the presence simulation is displayed.

List of elements for the presence simulation

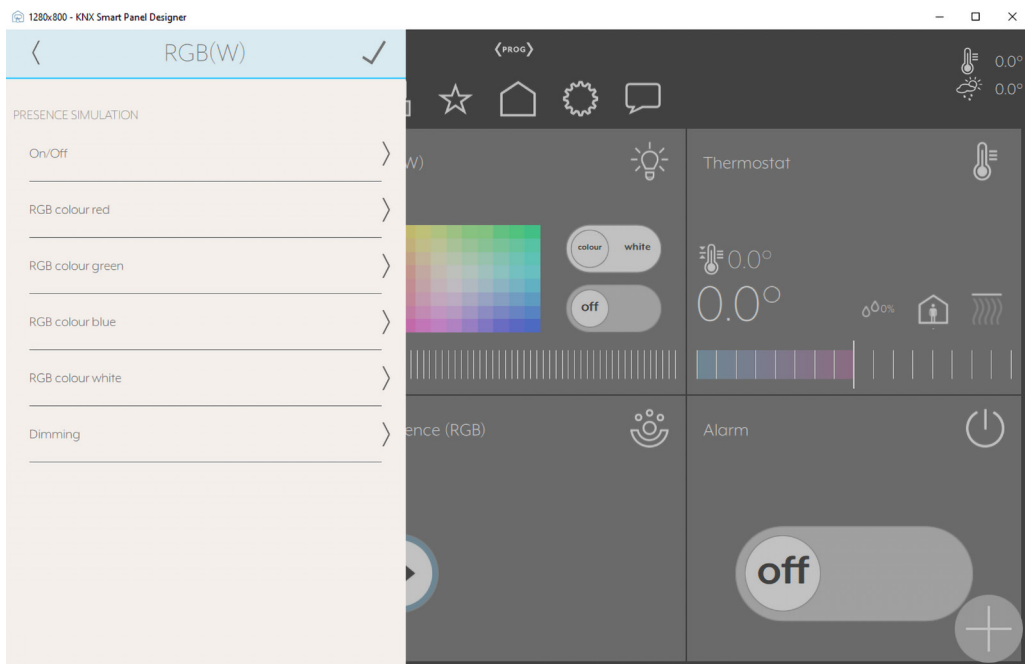

Fig. 50: Smart Panel Designer – List of elements for a presence simulation

- Select the element (function) for the presence simulation from the list. Recording and playback of the element is displayed.

Recording and playback of the element for presence simulation

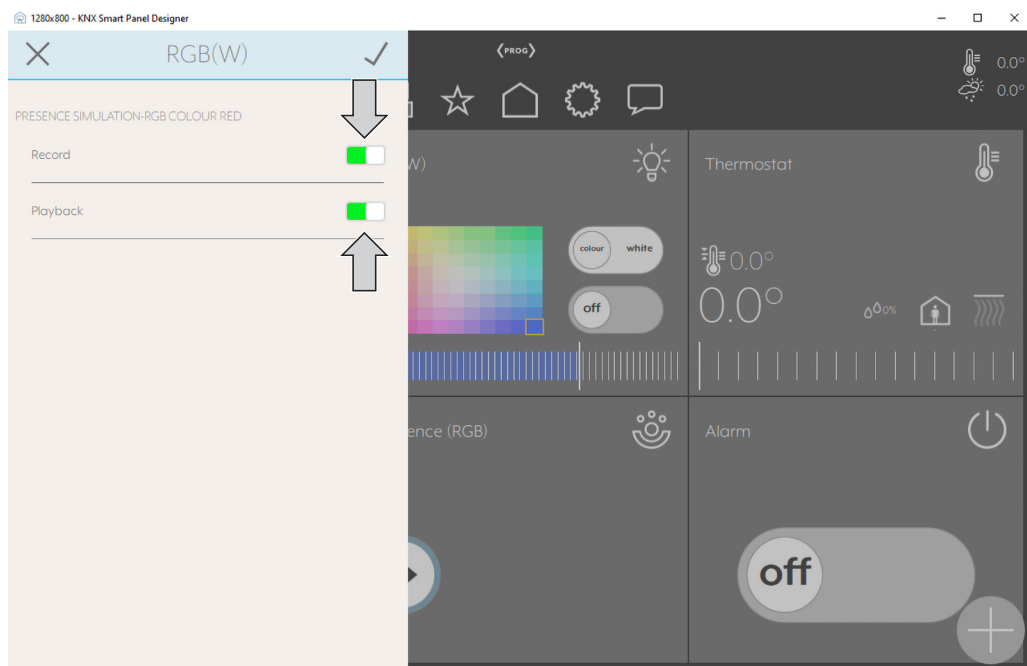

Fig. 51: Smart Panel Designer – Recording and playback of the element for presence simulation

- Activate recording and playback of the element for presence simulation.
The configuration (Playback, Record and Edit) of the presence simulation cannot be performed in the “Jung Smart Vision” app.
Description see page 66

“Sequence push-button” submenu

Settings → Configuration → Plugins → Sequence push-buttons

This function sets up a connection between physical buttons on the KNX bus and sequences created in a JUNG Smart Vision in such a way that, on pressing a button, the sequence assigned to this button is executed.

Requirements for the function:

- 1 byte (0-255) group address, the listener, similar to that for the KNX scenes
- One or more KNX buttons, which, on “pressing”, transmit a numerical value to the above address
- The function can be activated in the sequence parameters.
- Optional for buttons equipped with RGB LEDs, a group address (which can also group together multiple LEDs on the ETS level) of type DPT 232 (3 bytes).

IMPORTANT:

The configuration (coupling with a physical push-button) of the sequence push-buttons cannot be performed in the Smart Panel Designer.

Only the preparations for this can be performed in the Smart Panel Designer.

The configuration must be performed in the “Jung Smart Vision” app.

Description see page 73

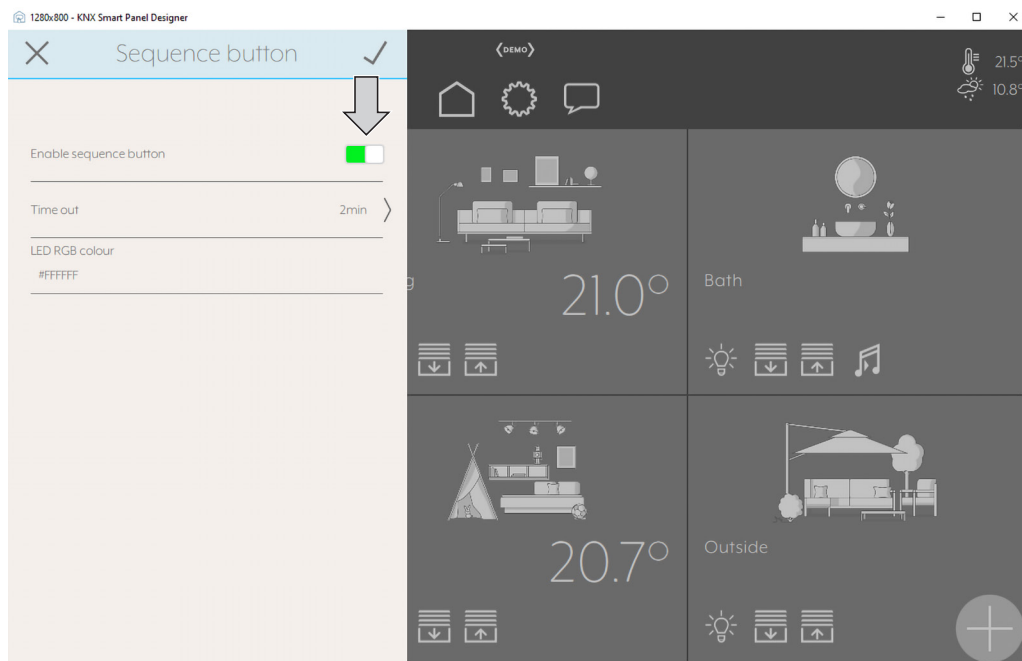

Fig. 52: Smart Panel Designer – “Sequence push-button” submenu

- Activate the sequence push-button with the toggle switch.
- Select timeout as an option.
The timeout is the time by which the coupling with a KNX button must be completed.
- Optionally, enter the LED RGB colour.
The colour must be entered as a hexadecimal value.
The prespecified value #FFFFFF corresponds to the colour “Standard White”.
- Confirm the settings with a checkmark.
Settings for the sequence push-button are applied.

Activating the sequence push-button for an element

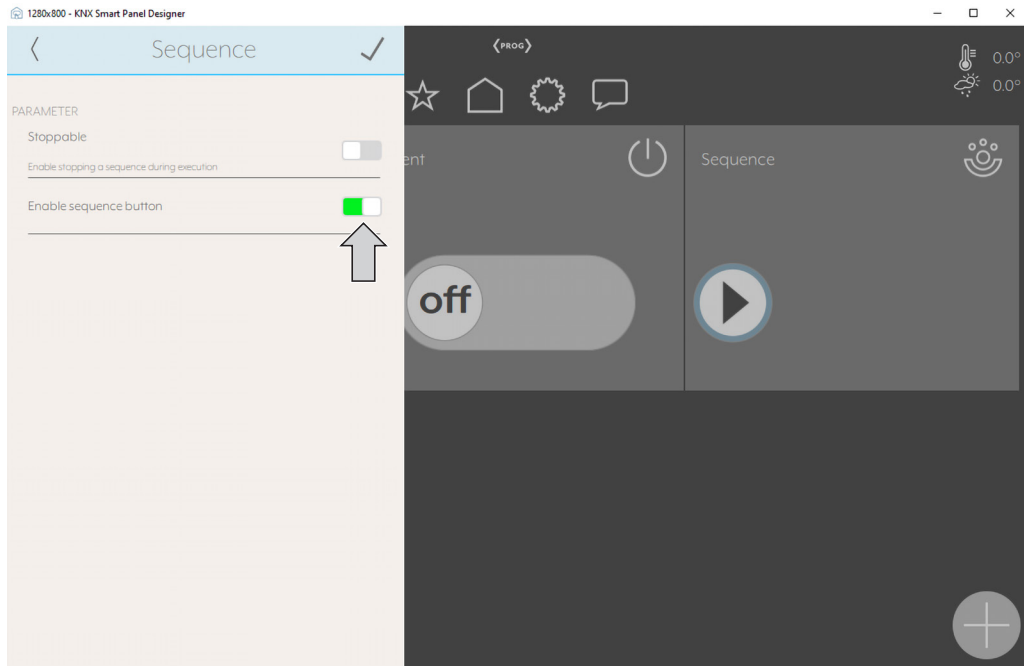

Fig. 53: Smart Panel Designer – Activating the sequence push-button for an element

- Select the “Parameters” menu in the settings of the appropriate sequence.
- Activate the sequence push-button with the toggle switch.
- Confirm the settings with a checkmark.
 Settings for the sequence push-button are applied.
 The configuration (coupling with a physical push-button) of the sequence push-buttons must be performed in the “Jung Smart Vision” app.
 Description see page 73

“Export/Import” submenu

Settings → Configuration → Export/Import

Here, the project itself is managed. Exporting corresponds to saving the project in a *.ksp file. Importing corresponds to downloading a saved project, in which the current project is replaced.

Resetting restores the project configuration to the factory setting (reset), i.e. all the changes are deleted and a new project can be created.

Export: Export visualisation project in the *.ksp file format

Import: Import visualisation project in the *.ksp file format

Reset: Delete the visualisation project and reset data

NOTE:

The *.ksp project file, including the visualisation, is imported into the ETS later on via the DCA, in order to program the KNX Smart Panel 8.

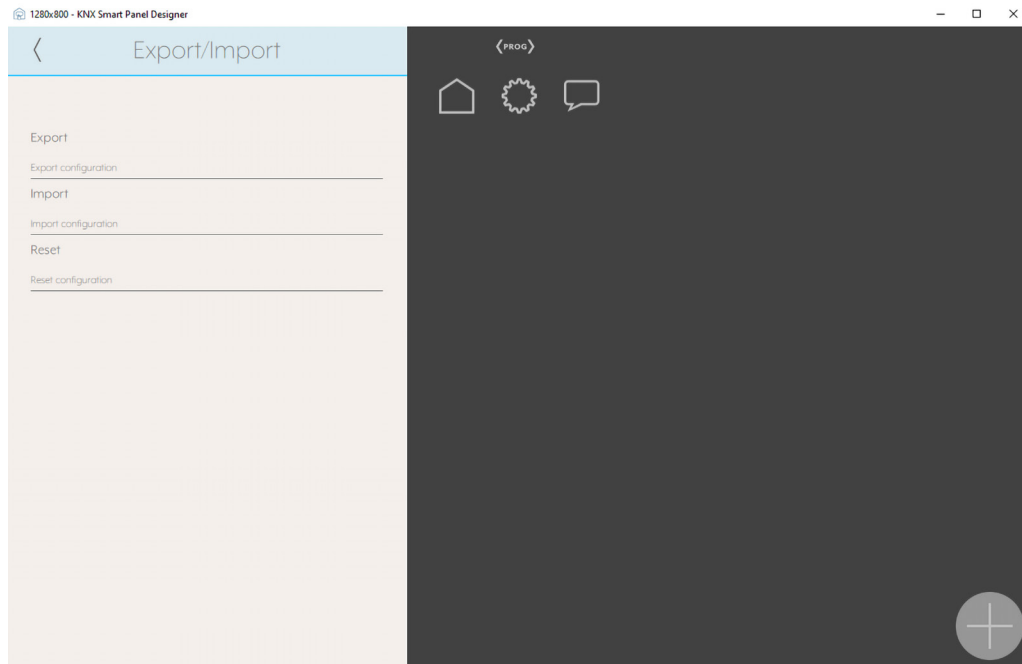

Fig. 54: Smart Panel Designer – “Export/Import” submenu

- Select Export, Import or Reset.
- Depending on the selection, select a folder for export, file for import or confirm a reset. Settings for the Export, Import or Reset are applied.

“App” submenu

Settings → App

The “App” menu contains further settings for the JUNG Smart Vision user interface.

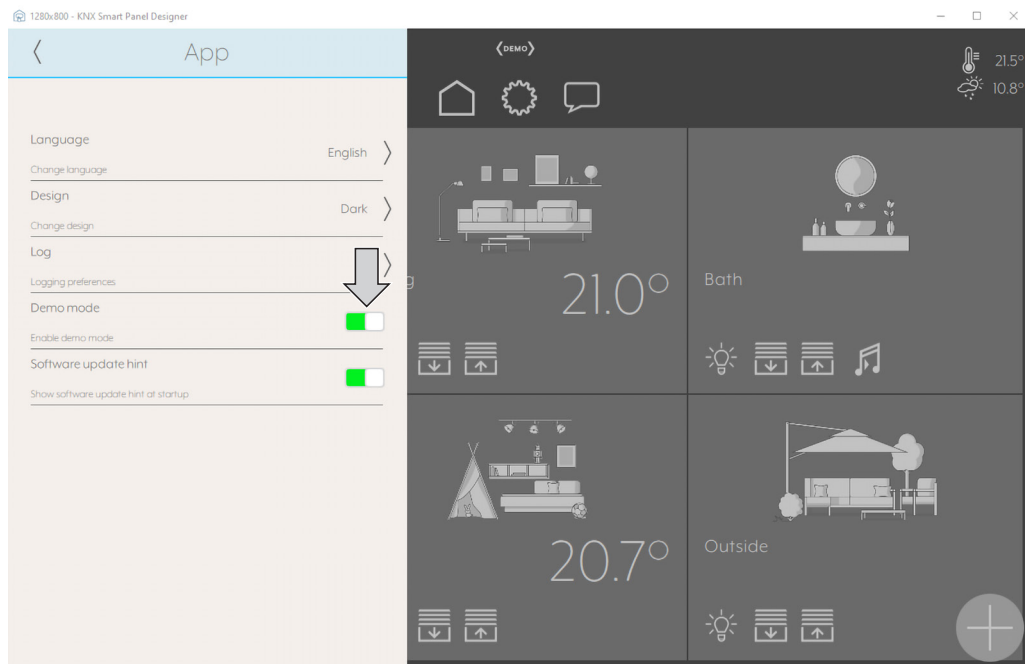

Fig. 55: Smart Panel Designer – “App” submenu

Demo mode

The appropriate mode can be activated under “Demo Mode” for demonstration and presentation purposes. After activation, prefabricated rooms, including elements, are created and displayed automatically.

An active Demo mode is displayed using the connection icon in the top status and navigation bar.

i The actual project is maintained, i.e. as soon as the Demo mode is left, the software changes back to the current project.

IMPORTANT:

When Demo mode is activated, the device cannot be programmed via the ETS (see “Export/Import” submenu on page 56). The Demo mode must be activated in advance. The same applies for the connection (coupling) with mobile devices (see “Pair” submenu on page 74).

- Activate or deactivate Demo mode using the toggle.
- Confirm the settings with a checkmark.
Settings for Demo mode are applied.

Software update information

Here, it is possible to activate or deactivate messages regarding the software update. If active, it appears each time the program is launched.

- Activate or deactivate software update information.
- Confirm the settings with a checkmark.
Settings for Software update information are applied.

“Language” submenu

Settings → App → Language

In the “Language” menu, the languages English, German and Spanish are available. The “Auto” option tries to select the language to be used later on by the operating system of the appropriate device. If this is not available, then English will be used as a fallback.

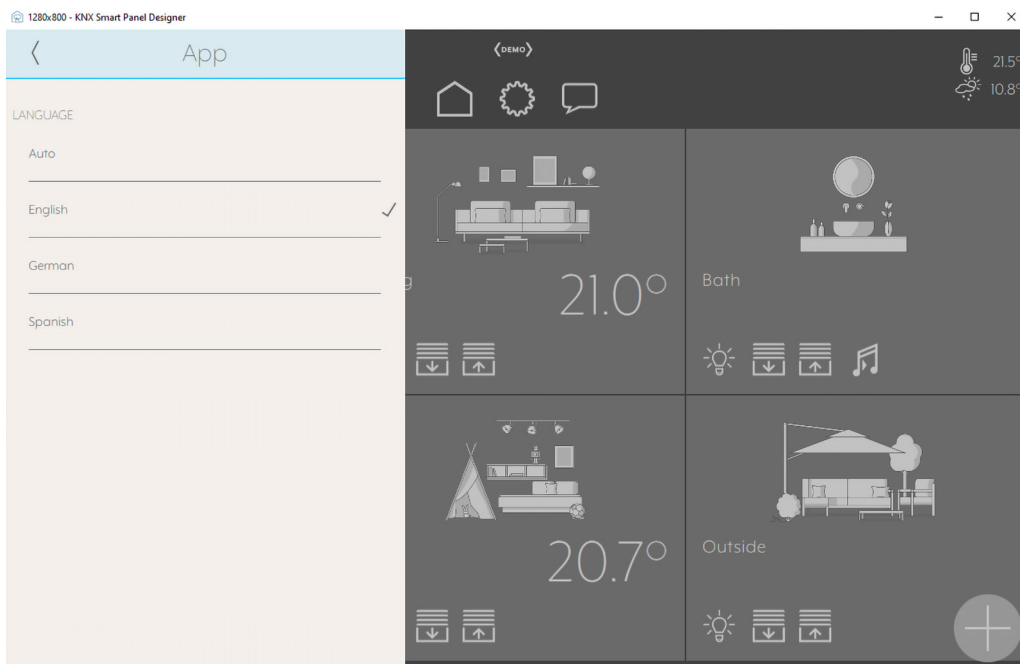

Fig. 56: Smart Panel Designer – “Language” submenu

- Select the language.
- Confirm the settings with a checkmark.
Settings for the language are applied.

“Design” submenu

Settings → App → Design

In the “Design” menu, you can switch between a light and dark colour scheme for the display of the user interface.

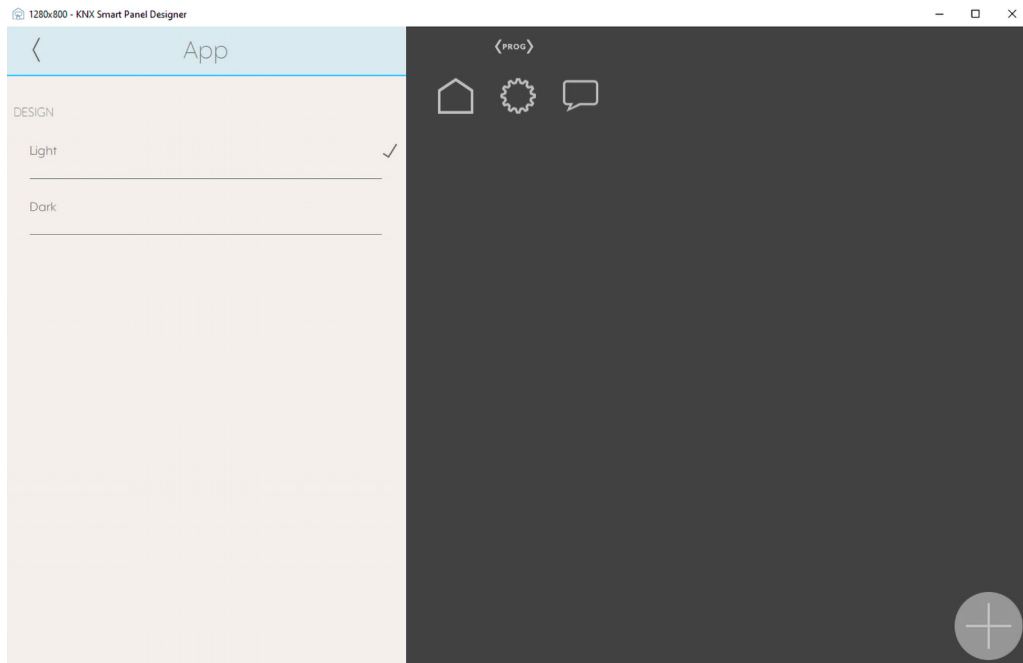
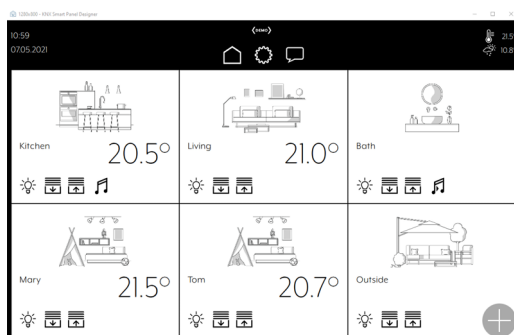
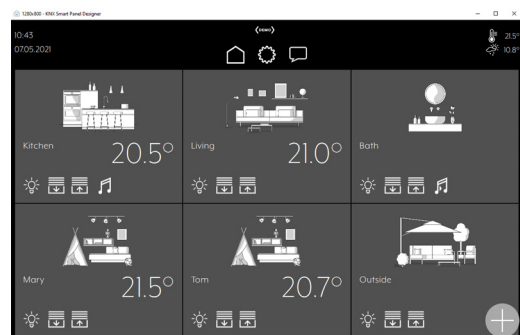

Fig.57: Smart Panel Designer – “Design” submenu

Light design



Dark design



- Select the design.
- Confirm the settings with a checkmark.
Settings for the design are applied.

“Log” submenu

Settings → App → Log

Application-specific logging can be activated and deactivated using “Log”. The logging applies only to the JUNG Smart Vision app or the software itself. As soon as logging has been activated, the two subitems “Log Level” and “Delete log files” can be operated.

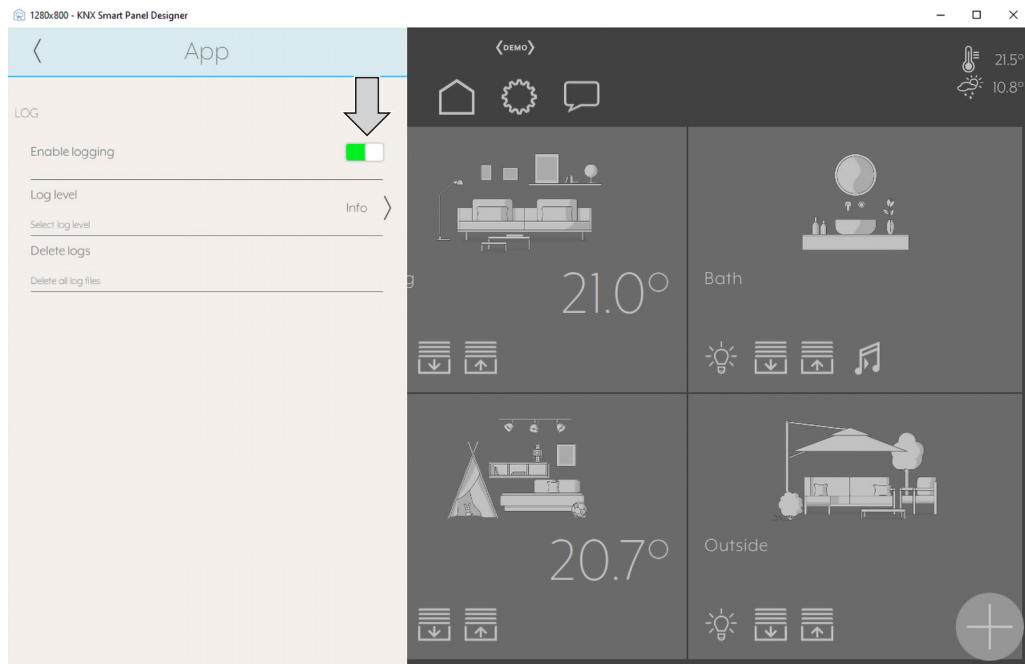

Fig. 58: Smart Panel Designer – “Log” submenu

The Log Level describes the system messages of the software to be written to the log file, from the lowest to the highest level. These messages are intended for support and analysis purposes and do not correspond to the messages on the user level.

Log Level	Explanation
Error	Messages with the Error level
Warning (standard)	Messages with the Error and Warning levels
Info	Messages with the Error, Warning and Info levels
Debug	Messages with the Error, Warning, Info and Debug levels
Advanced	Messages with the Error, Warning, Info and Debug levels and Advanced messages on the software

IMPORTANT:

The Log function should only be activated as required and subject to agreement with the Customer Centre and deactivated again after solving the problem, as it will otherwise place a long-term burden on the storage medium through write operations.

- Activate or deactivate the logs using the toggle.
- Optionally, select Log Level.
- Confirm the settings with a checkmark.
Settings for the logs are applied.

6.2 ETS and DCA

To link communication objects for the rooms and elements of the later user interface, the *.ksp project file created earlier in the KNX Smart Panel Designer must be imported into the ETS. The *.ksp project file is imported via the DCA.

This must take place separately for each KNX Smart Panel 8 in the ETS project.

Select the desired KNX Smart Panel 8 in the ETS project. Then, open the dialog for the project import in the "DCA" tab. Clicking "Import" opens the file selection. Then, you can select the *.ksp project file previously exported from the KNX Smart Panel Designer.

The appropriate communication objects are now generated for the selected device. Switching to the "Communications objects" tab offers access to the communication objects created by the imported configuration. The communication objects can be linked to other KNX devices in the ETS project.

IMPORTANT:

The DCA Version 1.0.102.0 or higher is required!

6.2.1 Downloading and installing

The DCA for the ETS must first be installed as an app.

The DCA is available via the KNX Online Shop at <https://my.knx.org/> .



Installation in the ETS takes place by adding it using the plus icon in the "Apps" menu, on the right-hand side in the lower Status bar.

As soon as the dialog for selecting the corresponding *.etsapp file appears, you can select the *.etsapp file and thus install the DCA.

Then, it is necessary to restart the ETS.

The product data must then be imported. The product database can be downloaded via the online catalogue or at <https://www.jung.de/> .

6.2.2 Activating ETS programming mode

As soon as all the links in the ETS have been set up, the device download can take place. Should this be the first download, then the ETS will request that Programming mode is activated on the device.

As soon as Programming mode is active, an appropriate note appears in the bottom right-hand corner of the display of the device. This note covers any other applications. This makes it clear that the device is in Programming mode.

The note is paired to the JUNG Smart Vision app and is only displayed when the JUNG Smart Vision app is running on the device. As soon as the device is in Programming mode, the download is performed in the ETS. After ending the ETS download, the Programming mode is automatically reset on the device. The JUNG Smart Vision app loads the newly-received configuration.

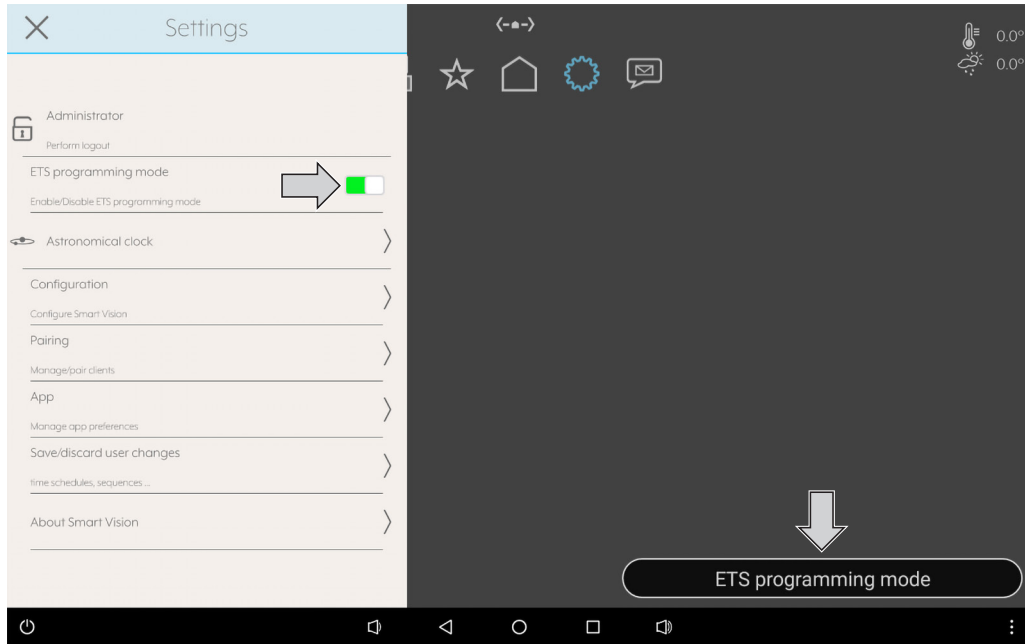

Fig. 59: JUNG Smart Vision – Activating ETS programming mode

Precondition:

User is logged in as an Administrator.

- Activate ETS programming mode using the toggle switch in the “Settings” menu.
ETS programming mode is shown in every menu.
The ETS download to the device is started automatically.
The ETS programming mode is stopped automatically after the download.
ETS programming mode is hidden.

6.2.3 Deactivate “Overwrite sequences and time planning”

You can change time planning and sequences can be directly on the device.

The DCA offers the option of not writing user-specific data for “Sequences” and “Time planning” to the device during the download. For this, there is an option in the DCA, directly under the “Export” button.

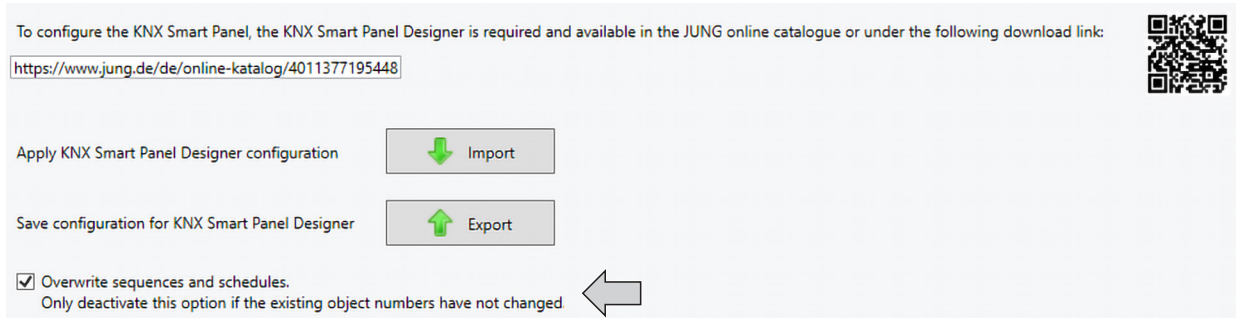

Fig. 60: ETS and DCA - “Overwrite sequences and time planning”

IMPORTANT:

If the configuration is changed completely but the time planning and sequences are not written to the device with the remainder of the configuration, it is possible that the existing data on time planning/scenarios on the device do not agree with the remaining configuration, leading to error messages!

6.2.4 Exporting the configuration from the ETA via the DCA

The data transferred to the ETS is saved in the appropriate project in the ETS database. If necessary, a configuration can be exported from the ETS and imported into the KNX Smart Panel Designer for further processing. For this, simply select the desired KNX Smart Panel 8 in the ETS project and click “Export” in the DCA. In so doing, a *.ksp file is generated, which can then be imported in the KNX Smart Panel Designer under “Configuration → Export/Import → Import”.

The export exports additional data to the device, such as the physical address and the project name.

6.2.5 Export configuration without DCA and ETS from the device

It is possible to obtain the entire configuration of a device directly on the device, without the ETS. To do this, open the side menu of the JUNG Smart Vision app on the device using the cog icon, log in with the Administrator PIN (74269) and save a corresponding *.ksp file to a desired memory slot (e.g. USB stick on the rear side) under “Configuration → Export”.

Then, import the *.ksp file into the KNX Smart Panel Design, where it can be edited. All the data regarding the time planning and scenarios changed by the user are also copied. This can be directly processed further in the KNX Smart Panel Design and later overwritten on the ETS download to the device.

6.3 “JUNG Smart Vision” app – Advanced settings

After the visualisation project has been programmed to the device, additional settings are available for the JUNG Smart Vision app.

Overview of the menu structure

- Configuration
 - Drivers
 - Export

- Pair
 - Clients

- App
 - Autostart

6.3.1 Configure advanced settings

“Configuration” submenu

Settings → Configuration

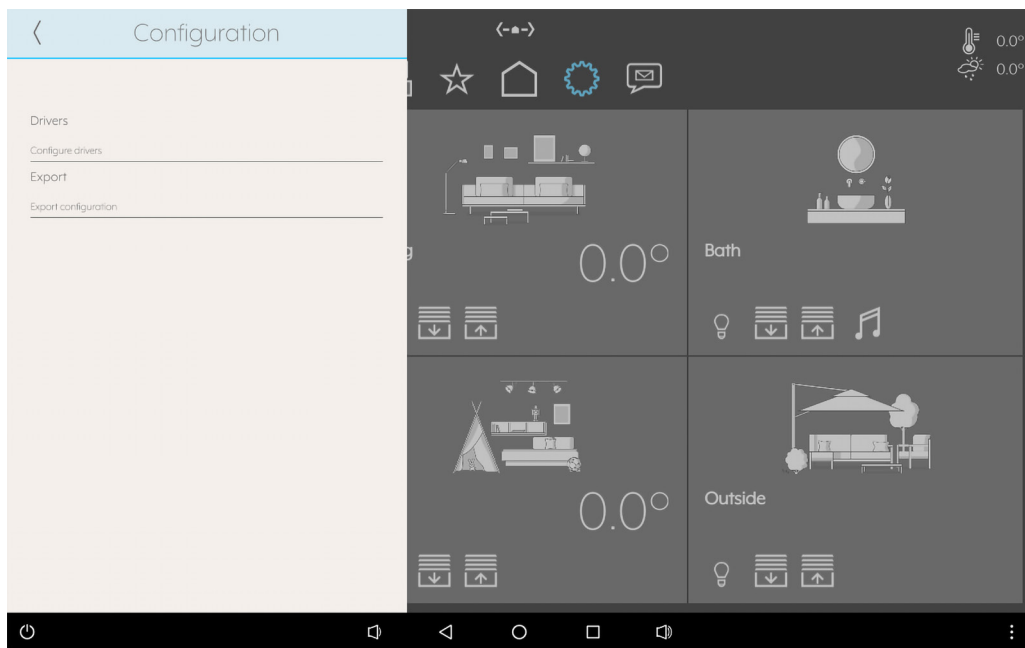

Fig.61: JUNG Smart Vision – “Configuration” submenu

“Drivers” submenu

Settings → Configuration → Drivers

The “Drivers” menu provides information on the current status of the KNX Twisted Pair (TP) connection between the device and the bus. This function is useful when trouble-shooting.

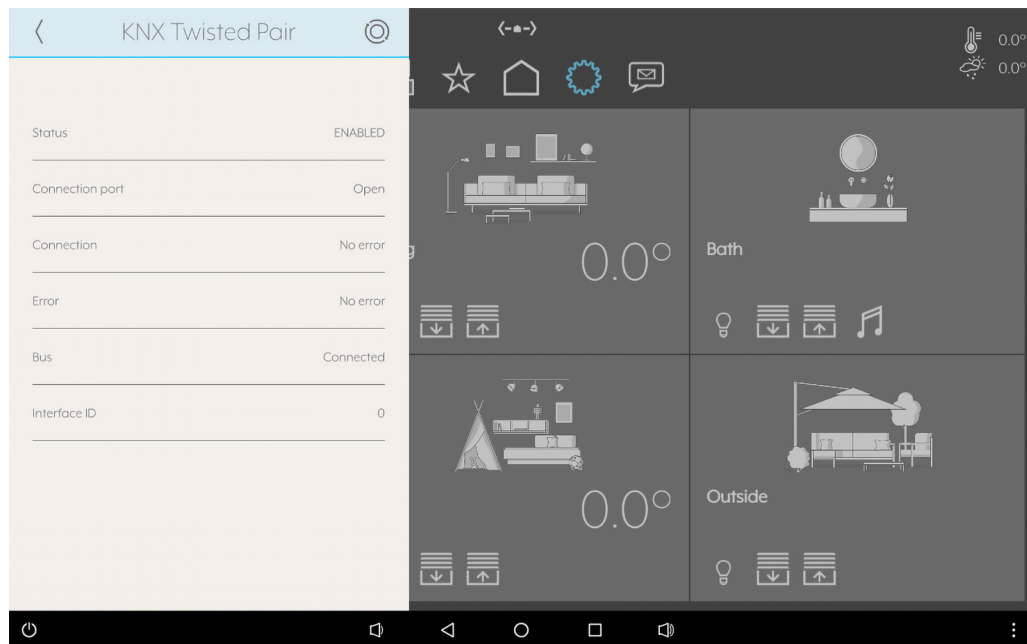

Fig. 62: JUNG Smart Vision – “Drivers” submenu

“Export” submenu

Settings → Configuration → Export

The “Export” menu corresponds to the “Export/Import” menu.

Description see page 56

6.3.2 Configuring the presence simulation (play back, record and edit)

IMPORTANT:

The preparations for the configuration of the presence simulation cannot be performed in the “Jung Smart Vision” app.

The preparations must be made in the Smart Panel Designer.

Description see page 50 ff

Preconditions:

The presence simulation is activated.

Elements were added to the presence simulation.

Recording and playback were activated for elements.

Record and playback mode of the presence simulation

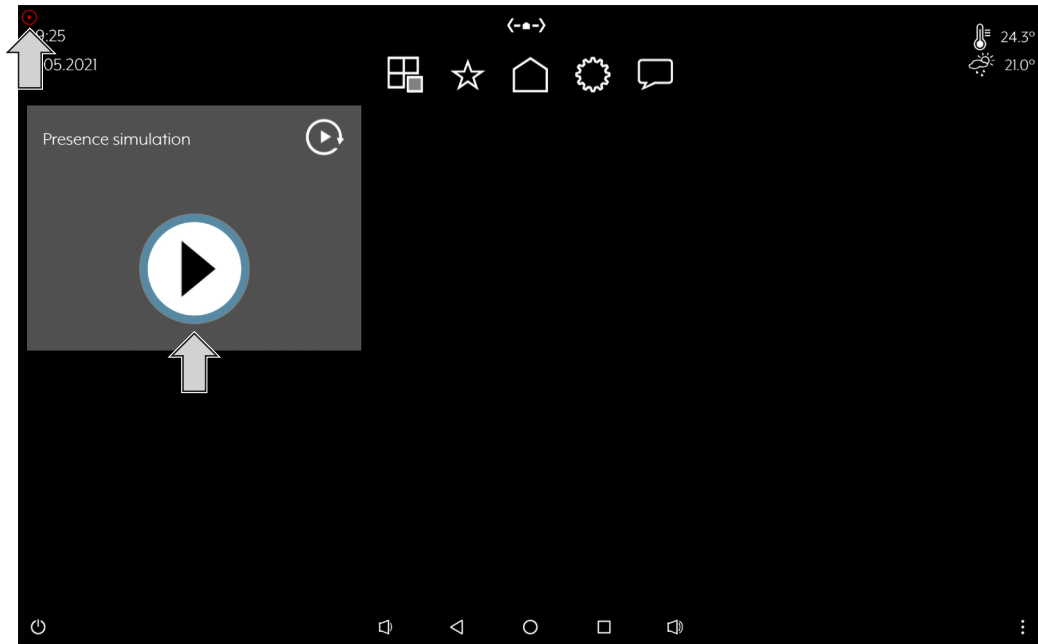

Fig. 63: JUNG Smart Vision – Record and playback mode of the presence simulation

As soon as recording is active, a pulsing red dot appears in the top left corner, above the information for the date and time. If the push-button on the user interface is pressed, playback mode starts. The icon in the top corner also changes to Playback mode. The icon within the push-button switches to Record mode.

Icon	Name	Explanation
▶	Playback	Playback mode of the presence simulation is activated
⦿	Recording	Record mode of the presence simulation is activated

Note:

The presence simulation is always in record mode after being activated.

During playback, the last week of recorded commands is played back, if available. If a day is not found, then the system jumps to the previous day until it finds a day actually containing commands. This means that the recording of a single day can also be used and played back each day.

The current mode (record/playback) is permanently saved in the database and, after a restart of the device, the saved most is applied directly after booting.

Display presence simulation

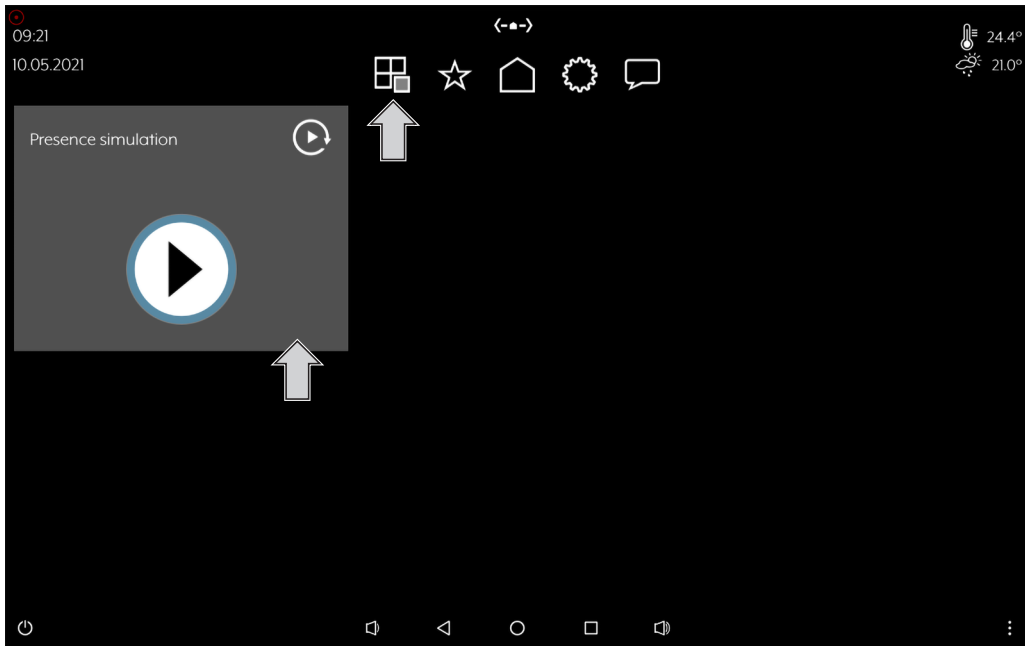

Fig. 64: JUNG Smart Vision – Display presence simulation

- Display the presence simulation using the plugin icon in the Status and navigation bar.
- Display the detail view of the presence simulation by left-clicking the tile. The detail view of the presence simulation is displayed.

Detail view of the presence simulation

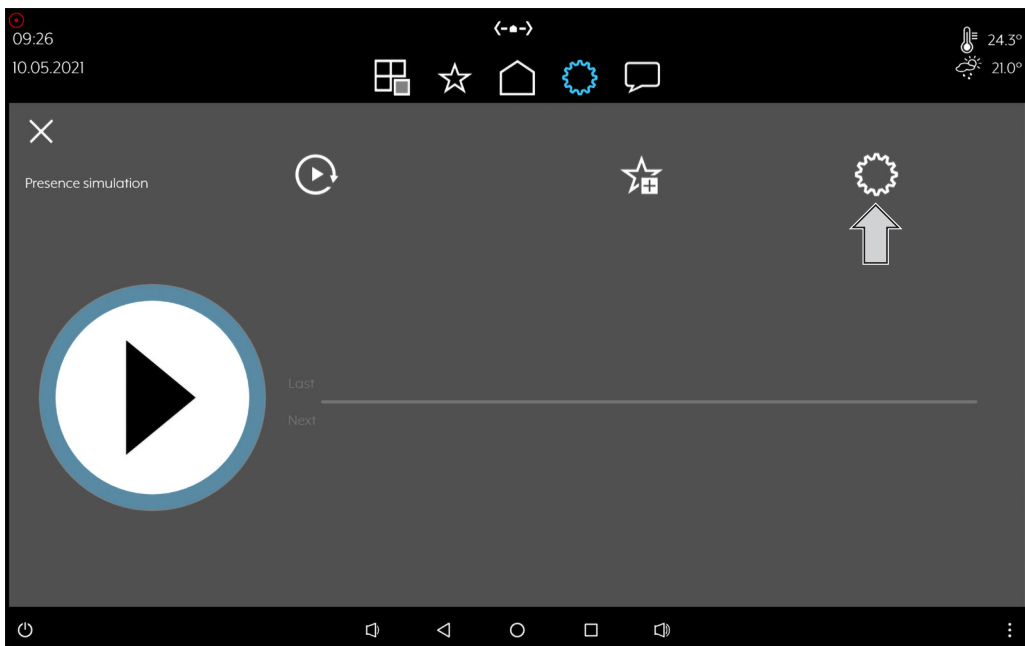

Fig. 65: JUNG Smart Vision – Detail view of the presence simulation

- Select the settings of the presence simulation. The settings of the presence simulation are displayed.

Settings of the presence simulation

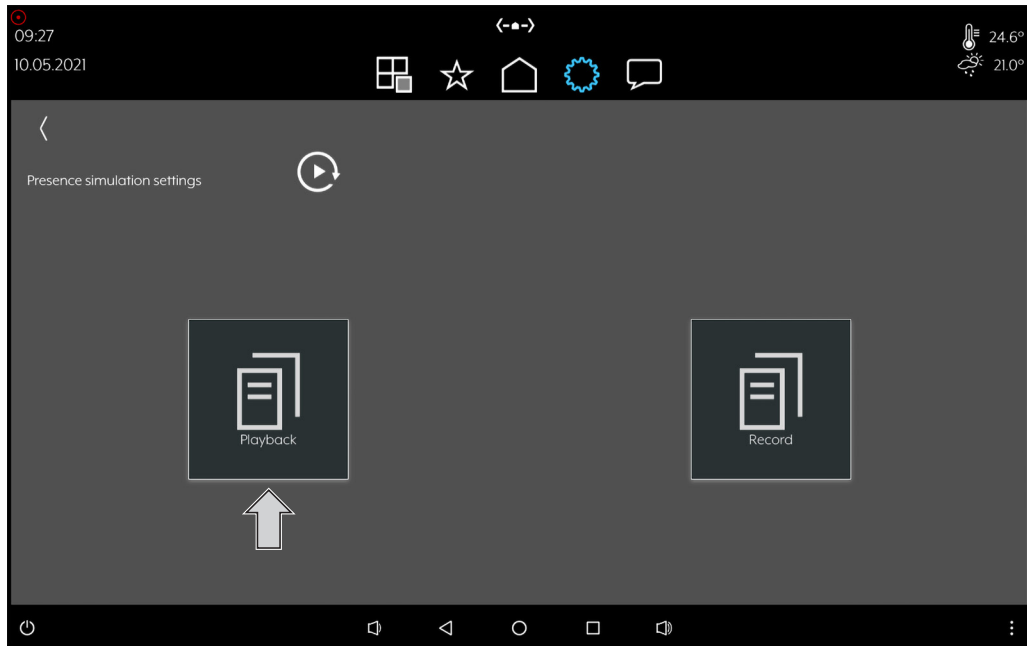

Fig. 66: JUNG Smart Vision – Settings of the presence simulation

- Select the playback of the presence simulation.
The playback of the presence simulation is displayed.

Playback of the presence simulation

In the “Playback” menu, it is possible to activate/deactivate individual functions of the presence simulation for playback. These are then removed accordingly from the playback. The settings can be made within the JUNG Smart Vision app on the Smart Panel.

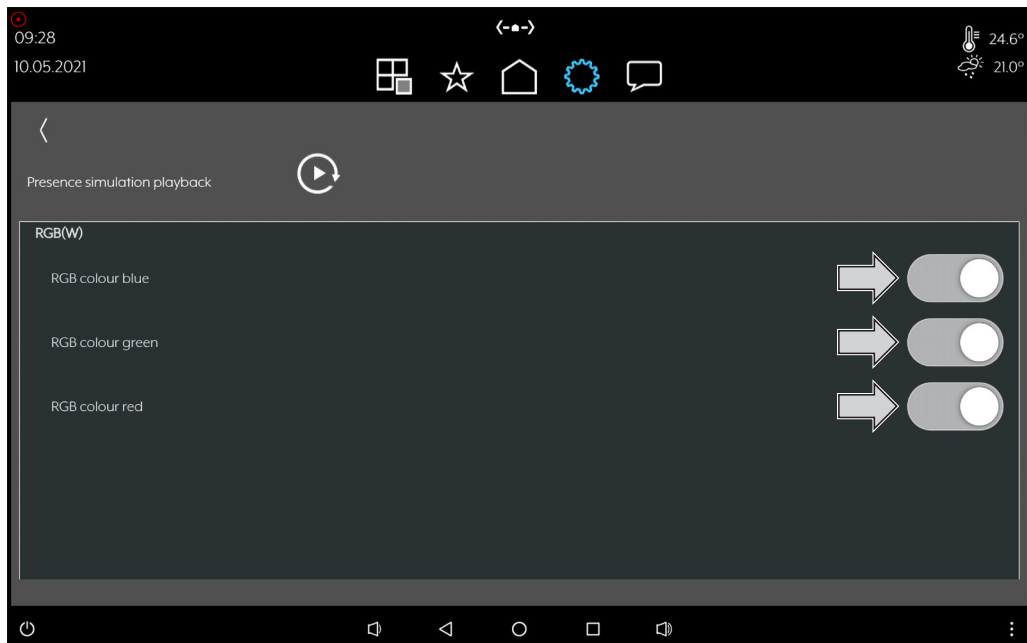

Fig. 67: JUNG Smart Vision – Playback of the presence simulation

- Activate or deactivate elements for the playback of the presence simulation with the toggle switch.

Recording of the presence simulation

The “Record” menu lists all previous, complete recordings of the presence simulation. Commands and/or actions can be added, edited or removed for hours or days.

The “Trash can” icon deletes all the recordings. Individual recordings and commands are deleted using the appropriate minus icon. Jumping to the appropriate day switches to the next lowest level: Day → Hour → Action

New actions can be added and edited manually using the plus icon. However, only the functions previously enabled in the KNX Smart Panel Designer can be selected for the presence simulation.

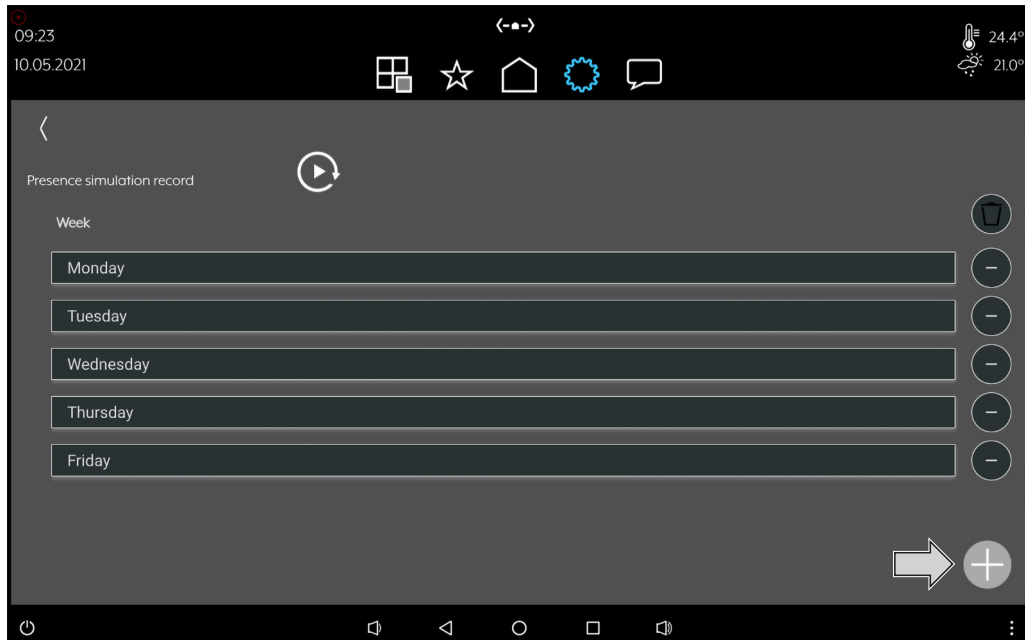

Fig. 68: JUNG Smart Vision – Recording the presence simulation

- Add a new action to the recording of the presence simulation using the plus icon. The new action for recording the presence simulation is displayed.

New action for recording the presence simulation

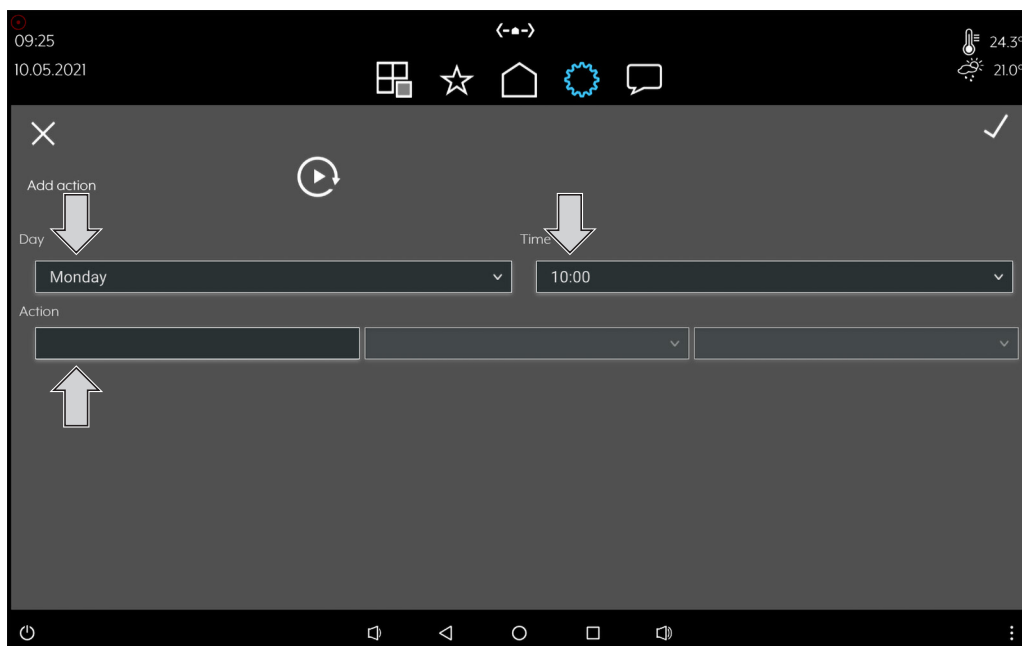

Fig. 69: JUNG Smart Vision – New action for recording the presence simulation

- Select the day and time of the new action.
- Enter the name for the new action and select the type of new action.
- Confirm the settings with a checkmark.
Settings for the new action for the presence simulation are applied.

Data structure of the recording

The recorded data is structured into periods:

- Week
 - Weekday
 - Section start
 - Time stamp (hour-minute) - Action details (data point, value)
 - Time stamp (hour-minute) - Action details (data point, value)
 - ...
 - Section end
 - Section start
 - ...
 - Section end
- ...

The sections are necessary to recognise whether there are valid recordings in this time period or not, and to react appropriately.

Each section is marked with a start and end mark. If one or other of these is missing, it means that the section is invalid. The KNX Smart Panel 8 can be switched off during the entire section. For this reason, no recording was possible during this section.

A section must start and end correctly to be valid. If a section is considered invalid, then a fallback method is used.

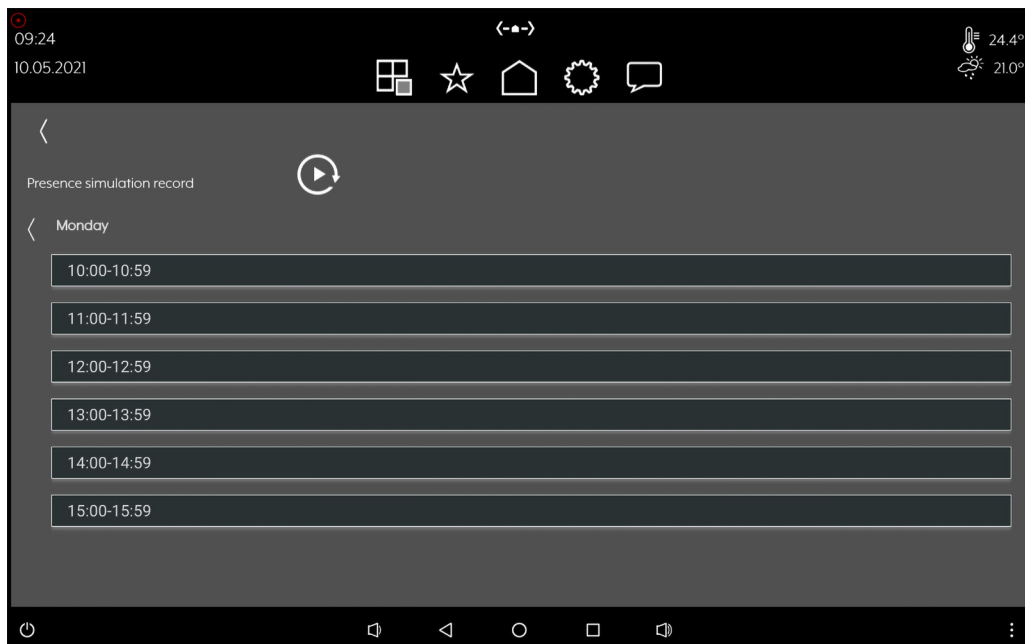

Fig. 70: JUNG Smart Vision – Data structure of the recording

Diagram of the data structure of the recording

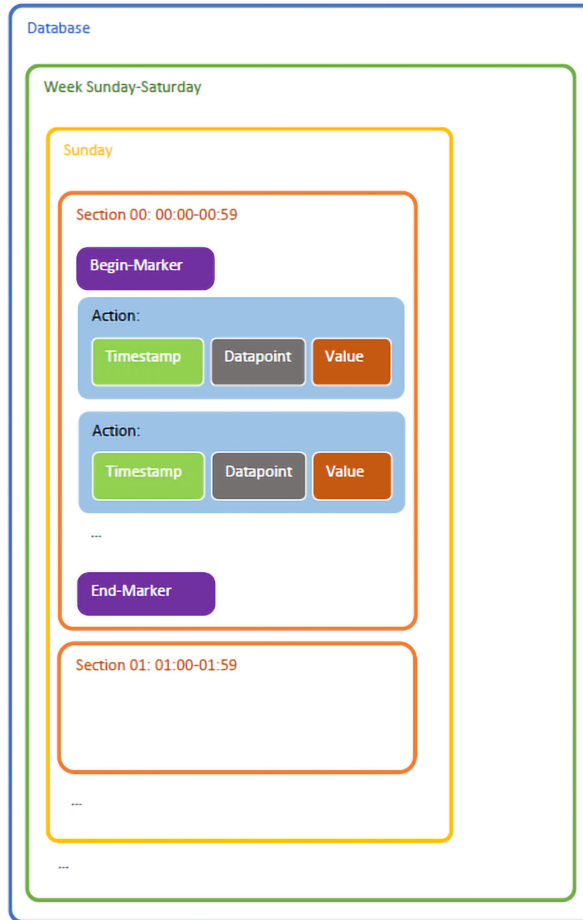

Fig. 71: JUNG Smart Vision – Diagram of the data structure of the recording

Restrictions and limitation

- Recording is limited to one week, assigned to weekdays.
- The time frame for a single period is 1 hour (recording).
- The maximum number of data points permitted for recording is 30 (thirty). The number of recordable data points varies from element to element.
- The maximum temporal resolution for recorded values of the same data points is 1 minute. If, during one minute, the same data point changes its value more than once, then the last received value will be recorded.

Recording cycle

Recording is always started at the start of the next time period (hh:00) after the switch to Record mode. To trigger the swapping of temporarily recorded data, the started period must end (hh:59). Otherwise, the swap will not be carried out and the recorded data is lost.

Playback cycle

Playback starts immediately after switching to Playback mode, irrespective of the start of the next time period.

The internal of the above loop is 1 minute.

IMPORTANT:

After each change to the data point level (changes in the ETS; re-import or additions), it is the responsibility of the system integrator to delete the current recording if the presence simulator is active and recording! This prevents playback from sending commands which may, for example, have changed their impact, because they have been assigned to a different KNX subscriber.

6.3.3 Configuring the sequence push-button (pairing with a physical push-button)

IMPORTANT:

The preparations for the configuration of the sequence push-button cannot be performed in the “Jung Smart Vision” app.

The preparations must be made in the Smart Panel Designer.

Description see page 54 ff

Information on preparing the ETS:

A specific value must be programmed in the ETS, which is transmitted to the address of the “Listener” on pressing a button.

The “Listener”, which now receives a value through the pressing of the button, records the combination of the received value and the currently opened sequence and saves it.

IMPORTANT:

Two corresponding communication objects for the project import and generated for the linking of the sequence push-button within the ETS.

Description see page 88

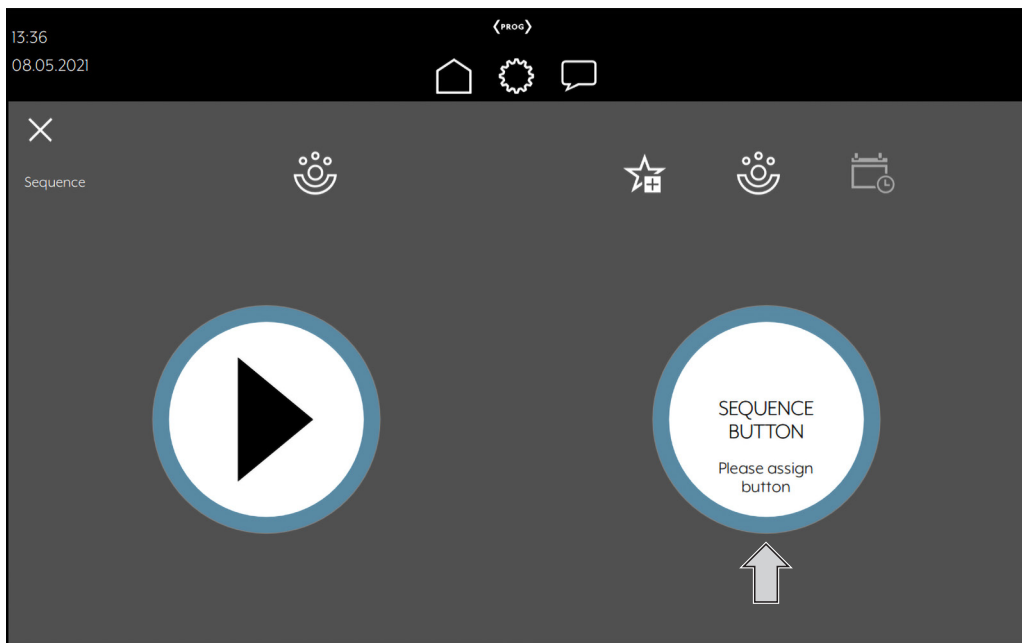

Fig. 72: JUNG Smart Vision – Configuring the sequence push-button

Preconditions:

User is logged in as an Administrator.

Values for the Listener must be programmed in the ETS.

- In the detail view of the appropriate sequence, select the sequence push-button.
The time for the pairing of the sequence push-button with a physical button starts.
As orientation, one of more LEDs of the buttons light up.
- Press the button for pairing with a sequence push-button.
The button must be pressed before the timer ends.
The timer is preset to 120 seconds.
The sequence is executed each time the button is pressed.

6.3.4 Pairing the Smart Panel with a mobile terminal (client)

Preconditions:

User is logged in as an Administrator.

The visualisation project is programmed into the device via ETS.

The Smart Panel and mobile terminals are in the same local network (LAN, Wi-Fi).

“Pair” submenu

Settings → Configuration → Pair

Besides the purely stand-alone system to the KNX controller, the KNX Smart Panel 8 also functions as a server for other mobile terminals, in order to allow operation of the KNX visualisation via the JUNG Smart Vision app. The device can be connected quickly and simply with the smartphone or tablet. The precondition in the JUNG Smart Vision app on the appropriate mobile terminal. The app can be downloaded via the Google Play Store (Android) and Apple Store (iOS).

IMPORTANT:

To pair mobile terminals, a local network (LAN, Wi-Fi) is essential! The KNX Smart Panel 8 must be locally connected via an appropriate network cable. Mobile terminals must be located in the same network. Remote access via the Internet is currently not possible.

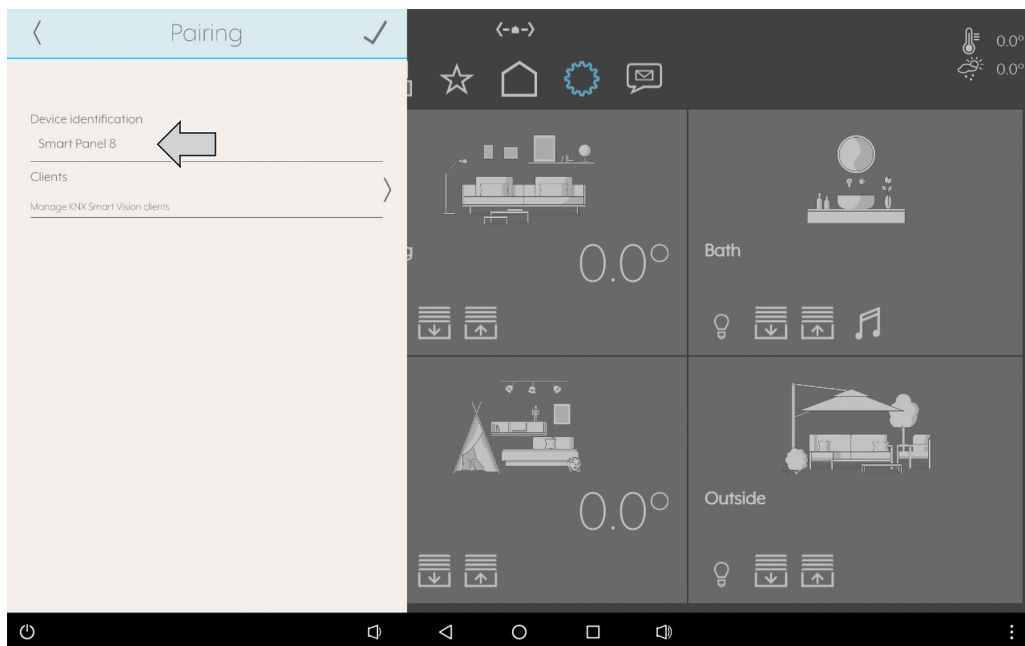

Fig. 73: JUNG Smart Vision – “Pair” submenu

- Enter the device ID.

“Clients” submenu

Settings → Configuration → Pair → Clients

New mobile terminals can be created in the “Clients” menu. A maximum of 10 app users (clients) per installation can be connected to the device. New clients are created using the plus icon.

All the clients are displayed within the list view. In addition, the system shows whether the access for the appropriate client is currently activated or not. A “long press” on the client name within the list causes the option to appear for the deletion of the appropriate client.

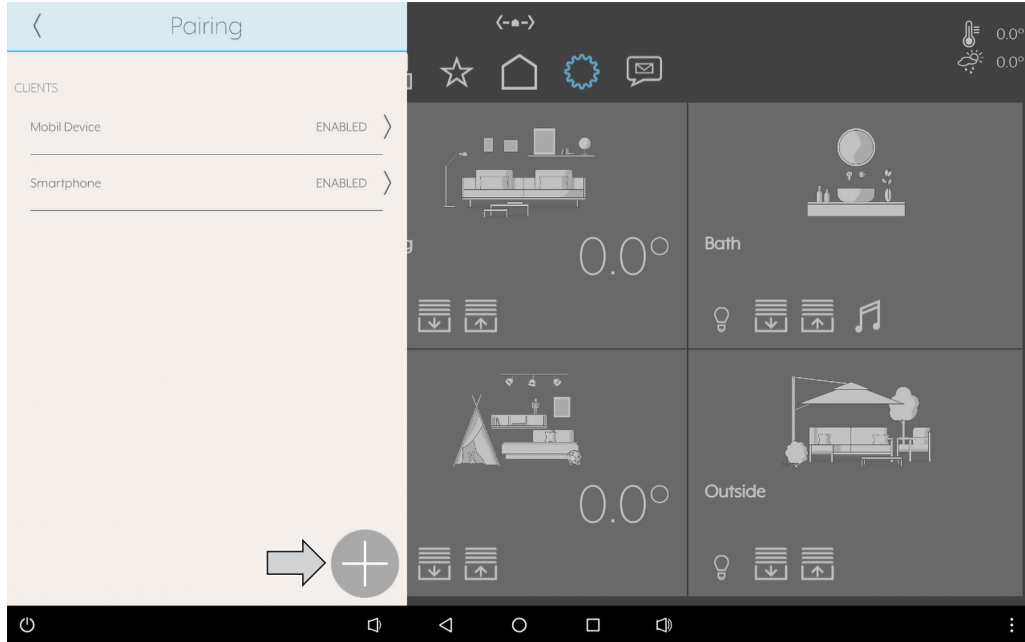

Fig. 74: JUNG Smart Vision – “Clients” submenu

- Add a new client using the Plus icon.
The “Add client” submenu is displayed.

“Add client” submenu

Settings → Configuration → Pair → Add client

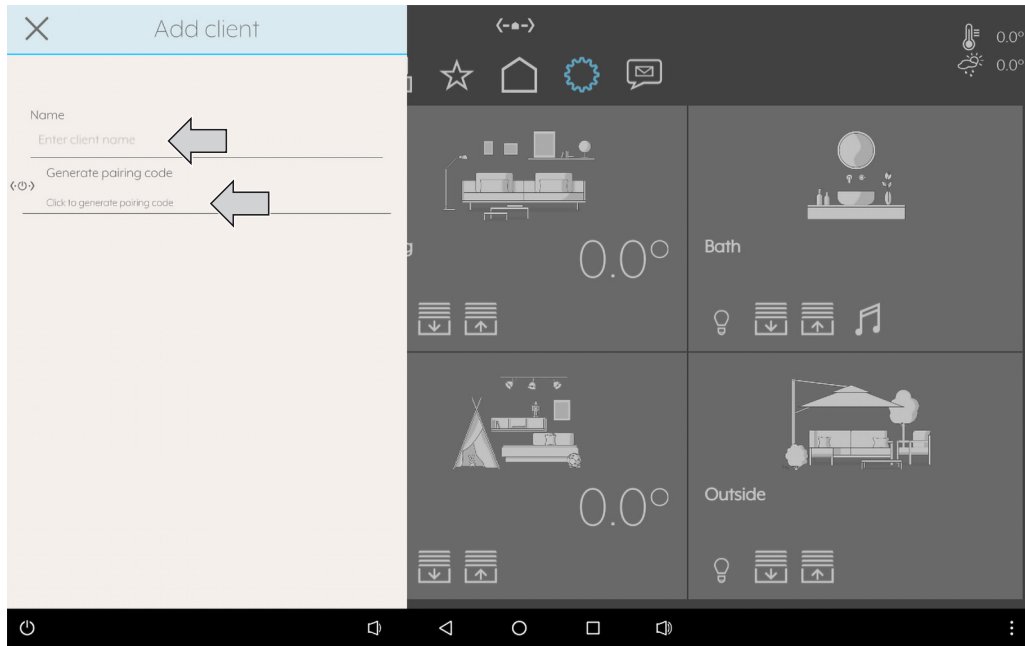
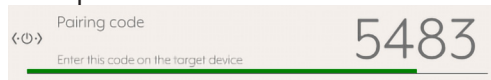

Fig. 75: JUNG Smart Vision – “Add client” submenu

- Enter the name for the client.
- Generate the pairing code.
The pairing code is displayed.

Example:



- Note down the pairing code for entry on the mobile terminal.
- Leave the menu open.

6.4 “JUNG Smart Vision” app – Mobile terminal (client)

6.4.1 Downloading and installing

The app can be downloaded via the Google Play Store (Android) and Apple Store (iOS). Then, the app can be installed on the mobile terminal.

6.4.2 Operation

The operation of the app on the mobile terminal corresponds to the operation of the app on the Smart Panel. You can find an overview of the areas of the app at page 13.

Further basic operation principles can be found here:

Open settings

Description see page 21

Log user in as Administrator

Description see page 22

The default Administrator password is: 74269

6.4.3 Pairing the mobile terminal (client) with the Smart Panel

“Devices” and “New device” submenus

Settings → Devices

Settings → Devices → New device

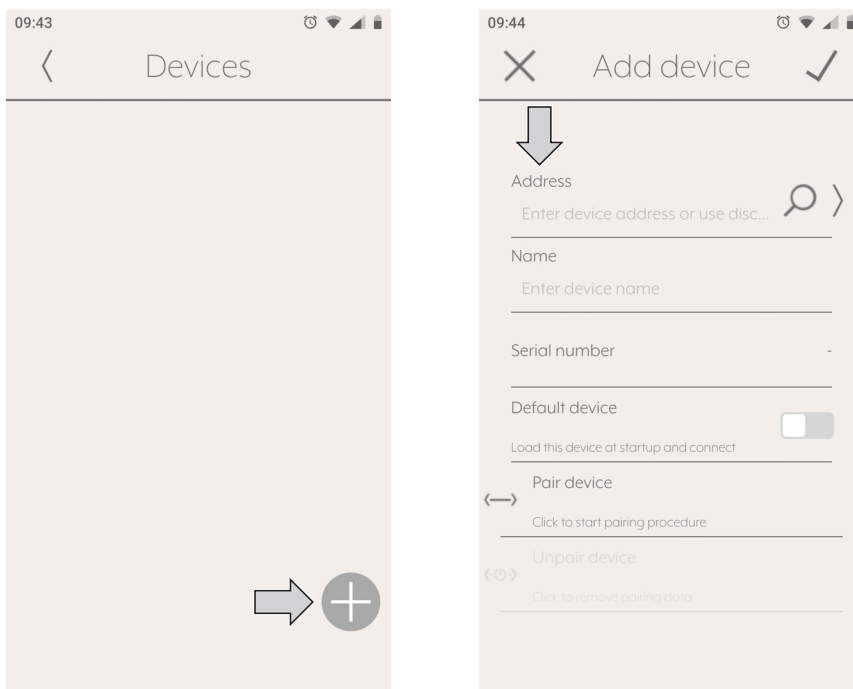

Fig. 76: JUNG Smart Vision – “Devices” and “New device” (client) submenus

Preconditions:

User is logged in as an Administrator.

The visualisation project is programmed into the device via ETS.

The Smart Panel and mobile terminals are in the same local network (LAN, Wi-Fi).

- Add a new device using the Plus icon.
The “New device” submenu is displayed.
- Select the address.
Available KNX Smart Panels are searched for automatically.
The list of found devices is displayed.

List of found devices and selected device in the “New device” menu

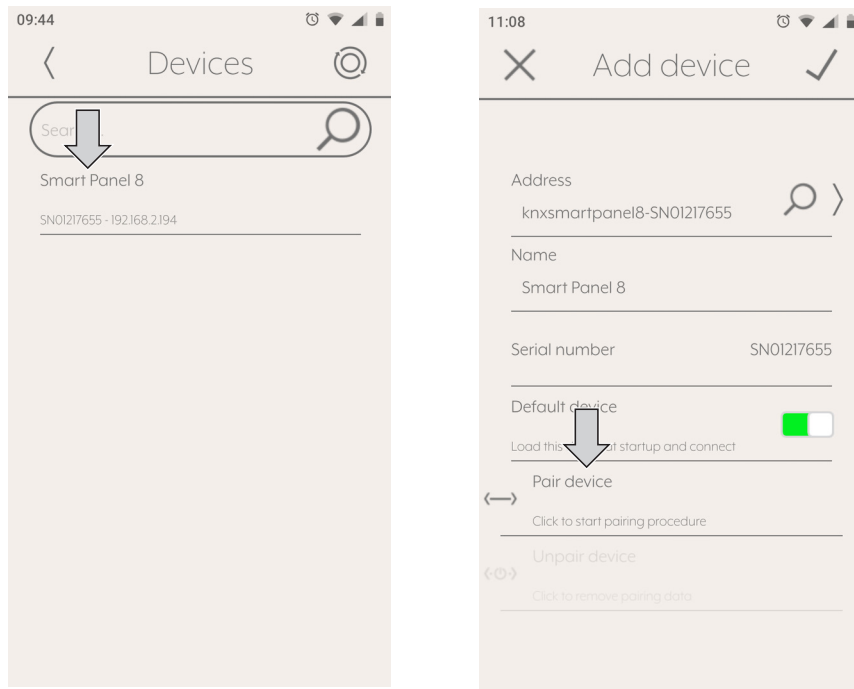

Fig. 77: JUNG Smart Vision – Found devices and selected device (client)

- Select the device for pairing from the list of the found devices.
The address, name and serial number of the selected devices are applied to the “New device” menu.
The “New device” menu is displayed.
 - i** If the searched for device is not displayed in the list, enter the IP address in the Search function and confirm it with the Search icon. Alternatively, press the Update icon via the Search function.
- Select “Start pairing”.
“Enter pairing code” is displayed.

“Enter pairing code” and paired device in the “Settings” menu

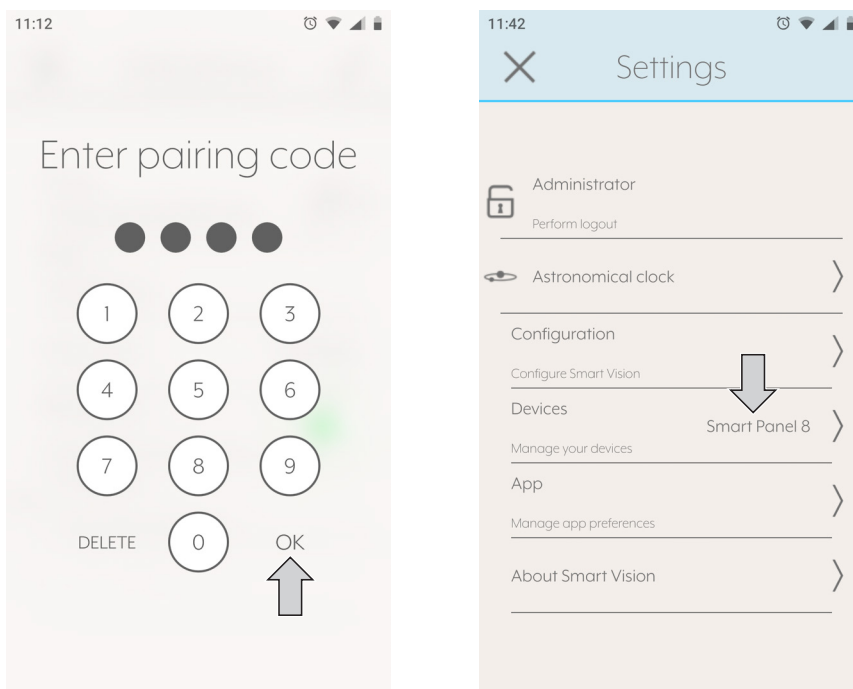

Fig. 78: JUNG Smart Vision – “Enter pairing code” and paired device (client)

- Enter the pairing code.
- Confirm the entry with “OK”.
The paired device is applied to the “Settings” menu and the “Devices” submenu.

Paired device in the “Devices” menu and editing the device

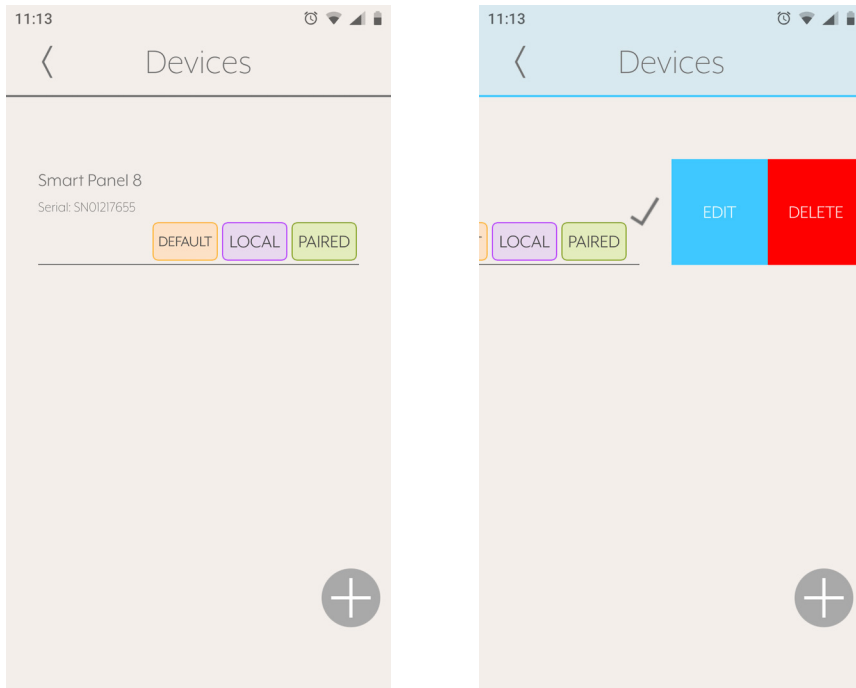





Fig. 79: JUNG Smart Vision – Paired device in the “Devices” menu and editing the device (client)

- To edit or delete the paired device, press it for a longer period of time. The “Edit” and “Delete” buttons are displayed.
- Confirm the settings with a checkmark.

Connection status between the mobile terminal (client) and the Smart Panel

Icon	Explanation
	Paired: Operation of the visualisation is possible
	Device automatically connected on launching the app
	Direct network connection (LAN) available

7 Communication objects

7.1 Data point types

The following data point types (DPT) are currently supported by JUNG Smart Vision:

ID	Length	Function
DPT 1	1 bit	Switch (on/off or up/down, etc.)
DPT 5	1 byte (%)	(0...100, 0...255 or 0...360°)
DPT 6	1 byte (%)	(-128...127)
DPT 7	2 bytes	(lux, mm, ms etc. 0...65535)
DPT 8	2 bytes	(time difference, rotation, etc. -32768...32767)
DPT 9	2 bytes (float)	Floating point values (-671088.64...670760.96)
DPT 10	3 bytes	Time
DPT 11	3 bytes	Date
DPT 12	4 bytes	0...4294967295
DPT 13	4 bytes	-2147483648...2147483647
DPT 14	4 bytes	4-octet float value IEEE 754
DPT 16	14 byte	Character string (max. 14 letters/symbols)
DPT 18	1 byte	Scene control
DPT 19	8 bytes	Time and date
DPT 232	3 bytes	RGB

IMPORTANT:

A maximum of 300 elements (rooms or functions) can be created.
 A maximum of 1,000 communication objects can be linked.

7.2 Elements and objects

On/off

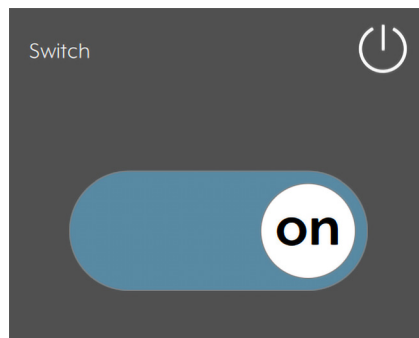

Fig. 80: Elements and objects – On/off

This element applies to any switch allowing two possible states. Under Parameters, you can find icons including labelling for additional personalisation.

DPT	Name	Object function	Length	Flags
1.001	On/off	Switch	1 bit	C-WTU
1.001	On/off status	Switch feedback	1 bit	C-W-U

Dimmer

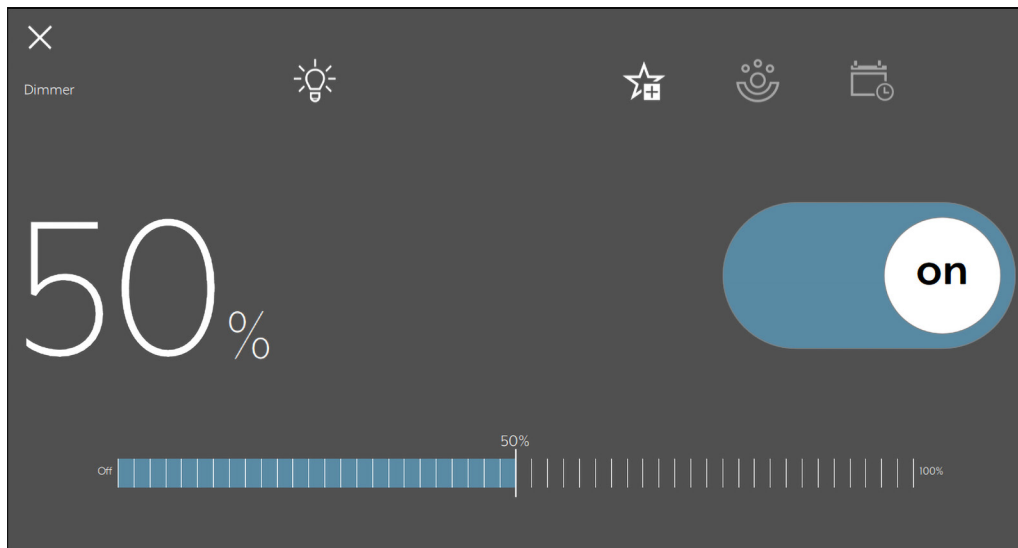

Fig.81: Elements and objects – Dimmer

This element type does not provide any parameters.

DPT	Name	Function	Length	Flags
1.001	On/off	Switch	1 bit	C-WTU
1.001	On/off status	Switch feedback	1 bit	C-W-U
5.001	Dimmer	percent (0 .. 100%)	1 byte	C-WTU
5.001	Dimmer status	percentage feedback (0 .. 100%)	1 byte	C-W-U

Shutter up/down

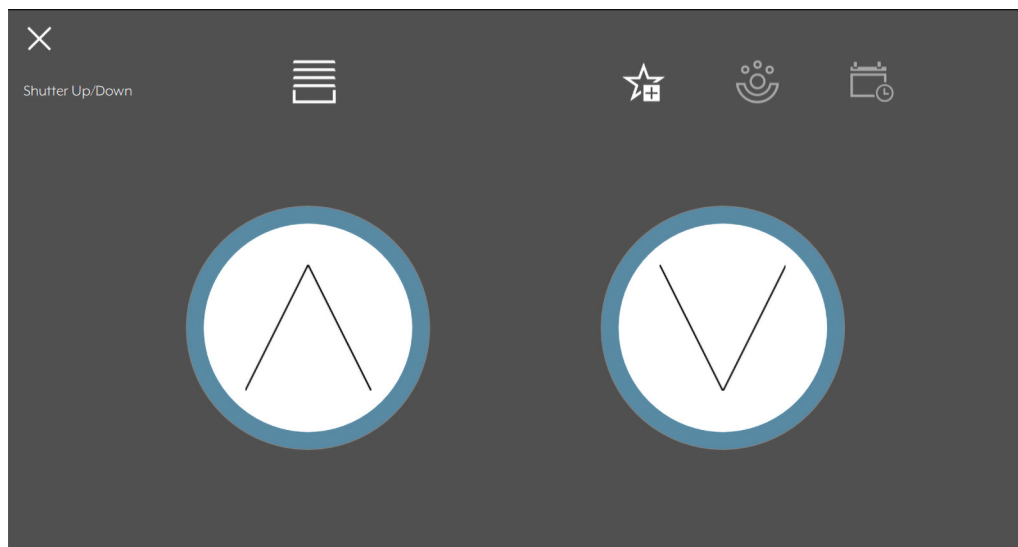

Fig. 82: Elements and objects – Shutter up/down

This element type does not provide any parameters.

DPT	Name	Function	Length	Flags
1.008	Shutter up/down	Up/down	1 bit	C-WTU
1.008	Shutter up/down status	Up/down feedback	1 bit	C-W-U
1.007	Shutter up/down step	Step	1 bit	C-WTU

Shutter, percentage

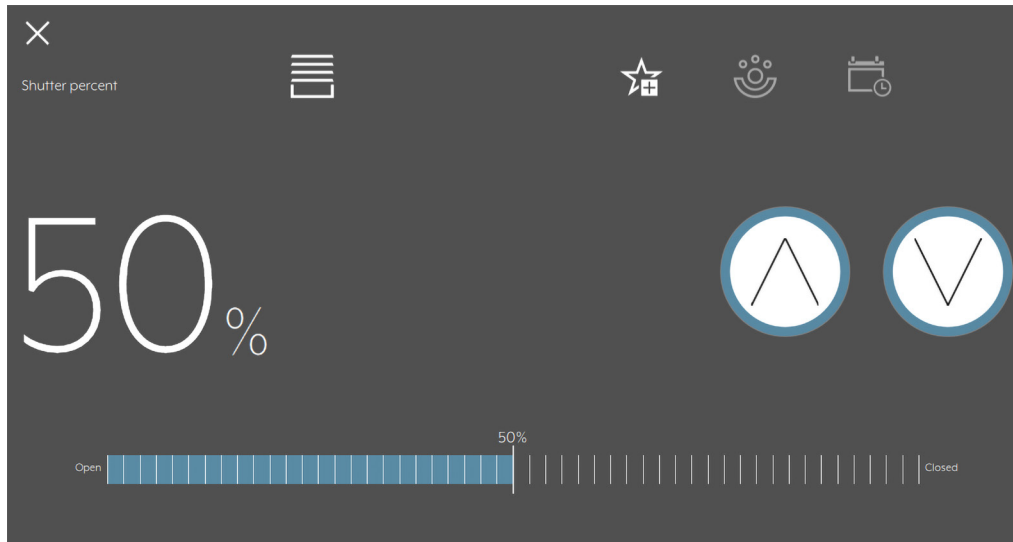

Fig. 83: Elements and objects – Shutter, percentage

This element type does not provide any parameters.

DPT	Name	Function	Length	Flags
1.008	Shutter up/down	Up/down	1 bit	C-WTU
1.008	Shutter up/down status	Up/down feedback	1 bit	C-W-U
1.007	Shutter up/down step	Step	1 bit	C-WTU
5.001	Shutter position	Percent (0 .. 100%)	1 byte	C-WTU
5.001	Shutter position status	Percentage feedback (0 .. 100%)	1 byte	C-W-U

Venetian blind

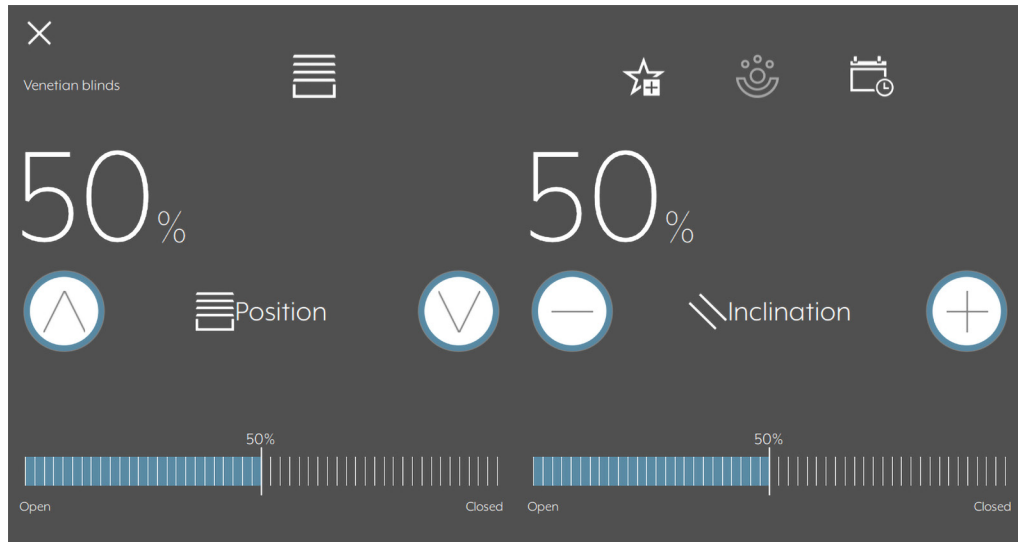

Fig. 84: Elements and objects – Venetian blind

This element type has two parameters:

- Venetian blind slider (activated/deactivated)
- Slats slider (activated/deactivated)

It offers up to 6 functions, which must be linked to matching data points.

This is the most complete element type for the control of Venetian blind actuators.

DPT	Name	Function	Length	Flags
1.008	Venetian blind up/down	Up/down	1 bit	C-WTU
1.008	Venetian blind up/down status	Up/down feedback	1 bit	C-W-U
1.007	Venetian blind up/down step	Step	1 bit	C-WTU
5.001	Venetian blind position	Percent (0 .. 100%)	1 byte	C-WTU
5.001	Venetian blind position status	percentage feedback (0 .. 100%)	1 byte	C-W-U
1.008	Slats up/down	Up/down	1 bit	C-WTU
1.008	Slats up/down status	Up/down feedback	1 bit	C-W-U
1.007	Slats up/down step	Step	1 bit	C-WTU
5.001	Slat position	Percent (0 .. 100%)	1 byte	C-WTU
5.001	Slat position status	Percentage feedback (0 .. 100%)	1 byte	C-W-U

RGB(W) – 3 x 1 byte colour and 1 x 3 byte colour

RGB + (W) + Dimmer

The displays for RGB (3 x 1 byte) and RGB (3 byte) are identical.

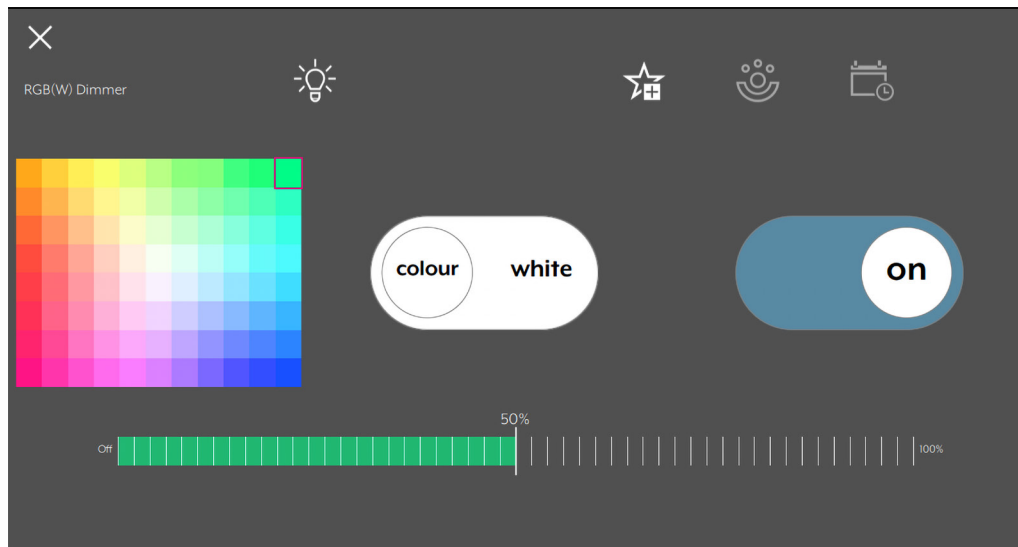

Fig. 85: Elements and objects – RGB(W)

This element type offers 2 parameters: The colour white (for RGBW devices) and the dimmer can be activated or deactivated. The data points for red, green and blue and that for switching on and off are fixed.

The following applies to the operation of RGB(W):

- Switch the colour/white switch to white and, using the slider at the bottom, adjust the value of the white colour (%).
- Switch the colour/white switch to colour and, using the slider at the bottom, adjust the brightness value (%) of the light.

It is possible to choose between RGB (3 x 1 byte) or RGB (3 byte).

DPT	Name	Function	Length	Flags
1.001	On/off	Switch	1 bit	C-WTU
1.001	On/off status	Switch feedback	1 bit	C-W-U
5.010	RGB colour red	Count impulses (0 .. 255)	1 byte	C-WTU
5.010	RGB colour red status	Count impulses feedback (0 .. 255)	1 byte	C-W-U
5.010	RGB colour green	Count impulses (0 .. 255)	1 byte	C-WTU
5.010	RGB colour green status	Count impulses feedback (0 .. 255)	1 byte	C-W-U
5.010	RGB colour blue	Count impulses (0 .. 255)	1 byte	C-WTU
5.010	RGB colour blue status	Count impulses feedback (0 .. 255)	1 byte	C-W-U
5.001	Dimmer	Percent (0 .. 100%)	1 byte	C-WTU
5.001	Dimmer status	Percentage feedback (0 .. 100%)	1 byte	C-W-U
5.001	RGB colour white	Percent (0 .. 100%)	1 byte	C-WTU
5.001	RGB colour white status	Percentage feedback (0 .. 100%)	1 byte	C-W-U
1.001	On/off	Switch	1 bit	C-WTU
1.001	On/off status	Switch feedback	1 bit	C-W-U
232.600	Colour RGB	RGB value 3x(0 .. 255)	3 byte	C-WTU
232.600	Colour RGB status	RGB value feedback 3x(0 .. 255)	3 byte	C-W-U
5.001	Dimmer	Percent (0 .. 100%)	1 byte	C-WTU
5.001	Dimmer status	Percentage feedback (0 .. 100%)	1 byte	C-W-U
5.001	RGB colour white	Percent (0 .. 100%)	1 byte	C-WTU
5.001	RGB colour white status	Percentage feedback (0 .. 100%)	1 byte	C-W-U

Thermostat

This element type is that with the broadest scope of function. The parameters include:

Mode (operating mode)	None AUTO-COM-PRE-ECO-OFF COM-PRE-ECO-OFF COM-STBY-NIGHT-FROST
Operating mode bits	Activate / Deactivate
Fan type	None On / Off (only status) Off / Speed 1-3 (only status) Auto / [Man Off/On] Auto / [Man Off/Speed 1-3] Auto / Man
Invert Fan auto/man	Activate / Deactivate
Activate setpoint value	Activate / Deactivate
Shared setpoint value (for heating and cooling)	Activate / Deactivate
Activate moisture display	Activate / Deactivate
Activate effective setpoint value	Activate / Deactivate
Activate status icon, Heating/cooling	Activate / Deactivate
Activate switch-over, Heating/cooling	Activate / Deactivate
Invert Heating/cooling	Activate / Deactivate
Activate setpoint value offset	Activate / Deactivate
Offset step width	Step width (setpoint value shift)
Min. value offset	Smallest value offset (setpoint value shift) (lower limit)
Max. value offset	Largest value offset (setpoint value shift) (upper limit)

Note:

Optionally, it is possible to activate individual operating mode bits (1-bit object incl. feedback) to switch over the operating mode. These are then available as communication objects within the ETS.

Full expansion level, thermostat (HVAC)

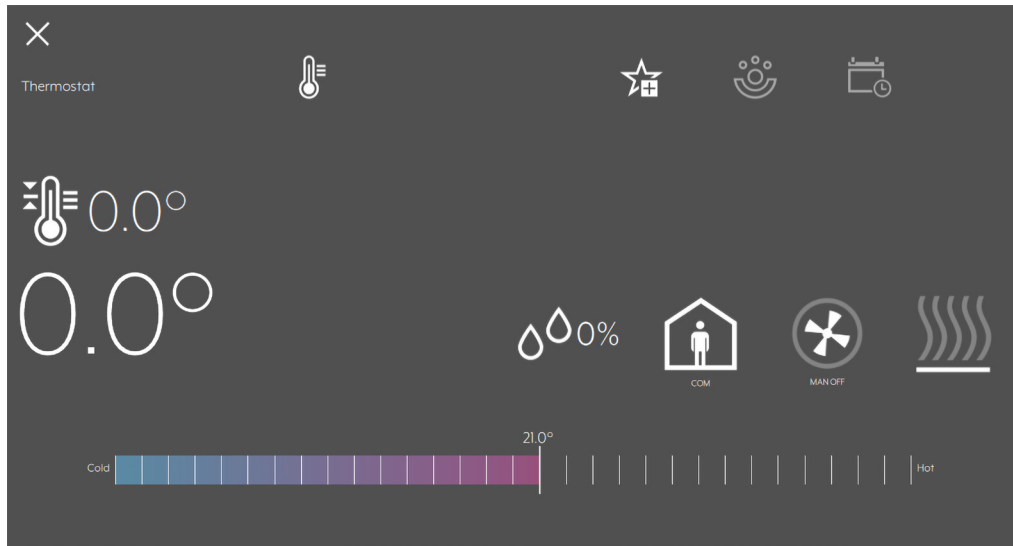

Fig. 86: Elements and objects – Thermostat

DPT	Name	Function	Length	Flags
9.001	Temperature status	Temperature (°C) feedback	2 byte	C-W-U
8 bit unsigned	Operating mode	Operating mode switchover	1 byte	C-WTU
8 bit unsigned	Operating mode status	Operating mode switchover feedback	1 byte	C-W-U
1.001	Fan on/off	Switch	1 bit	C-WTU
1.001	Fan on/off status	Switch feedback	1 bit	C-W-U
8 bit unsigned	Fan speed	Fan speed	1 byte	C-WTU
8 bit unsigned	Fan speed status	Fan speed feedback	1 byte	C-W-U
1.001	Fan auto/man	Switch	1 bit	C-WTU
1.001	Fan auto/man status	Switch feedback	1 bit	C-W-U
9.001	Setpoint value	Temperature (°C)	2 byte	C-WTU
9.001	Setpoint value status	Temperature (°C) feedback	2 byte	C-W-U
1.001	Cooling off/on status	Switch feedback	1 bit	C-W-U
9.001	Effective setpoint value status	Temperature (°C) feedback	2 byte	C-W-U
1.001	Heating on/off status	Switch feedback	1 bit	C-W-U
6.010	Setpoint value offset	Count impulses (-128 .. 127)	1 byte	C-WTU
6.010	Setpoint value offset status	Count impulses (-128 .. 127) feedback	1 byte	C-W-U
1.001	Cooling/heating	Switch	1 bit	C-WTU
1.001	Cooling/heating status	Switch feedback	1 bit	C-W-U
9.007	Humidity status	Humidity (%) feedback	2 byte	C-W-U

Sequence

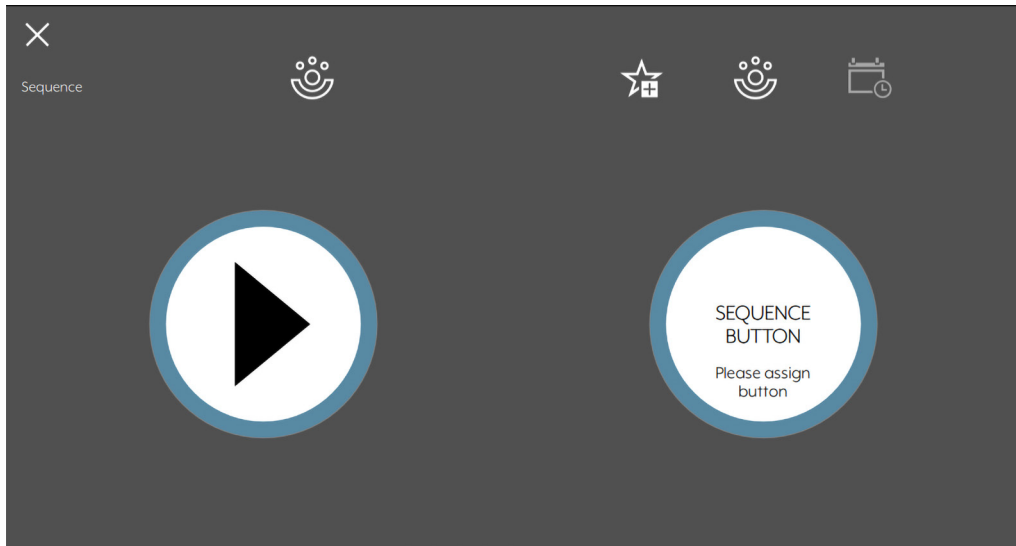

Fig. 87: Elements and objects – Sequence

This element offers the option of triggering a sequence (Description see page 35) using a physical push-button. Here, a 1-byte value is used, which must be written by the appropriate push-button to the corresponding communication object. The value is stored in the ETS for the physical push-button and taught in via the element on the visualisation.

As soon as this value is read by the KNX Smart Panel, the corresponding sequence is triggered. To be able to use the sequence push-button, it must first be activated via “Settings → Plugins → Sequence push-button”. To use the function in a sequence, it must be enabled in the appropriate element under “Parameters”.

DPT	Name	Function	Length	Flags
18.001	SYSTEM sequence push-button status	Scene control feedback	1 byte	C-W-U
232.600	SYSTEM sequence push-button LED	RGB value 3x(0...255)	3 byte	C-WTU

KNX scene

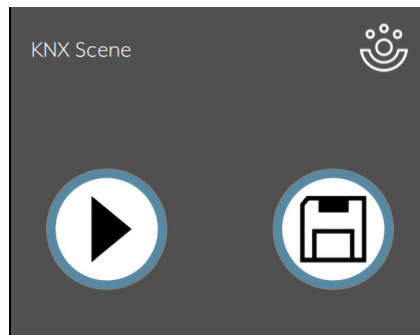

Fig. 88: Elements and objects – KNX scene

The functionality of the KNX scene is similar to that of the sequence but is more limited. The configuration of the KNX scene must be performed in the ETS. This element makes it possible to recall a specific scene corresponding to a number (from 1 to 64), which is also defined in the ETS programming level.

The parameters are:

- Teach (saves the current values of the involved functions)
- Scenario value (only for KNX – number of the scene to be recalled)

DPT	Name	Function	Length	Flags
18.001	KNX scene	Scene control	1 byte	C-WTU

Personalised slider

The personalised slider can be used for various purposes. The element can be used to write values to the bus (control element “Only slider”) or display values from the bus (control element “Only value display”) or both. An icon from the library can be used for the display.

The following parameters are available for the element:

Control elements	All (sliders and value display)
Measurement unit	Only slider
Decimal places	Only value display
Label min.	Displayed according to the value (e.g. °K)
Label max.	Number of decimal places
Min. value	Minimum value (smallest value of the value range)
Max. value	Maximum value (largest value of the value range)
Step width (ticks)	Value between two lines (scale)
Slider step width	Smallest possible shift of the slider

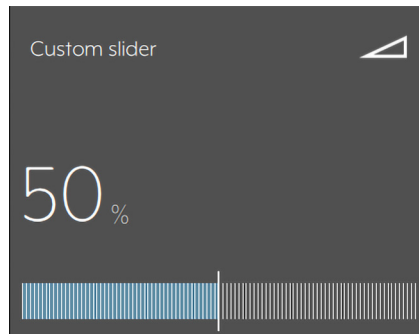

Fig. 89: Elements and objects – Personalised slider

DPT	Name	Function	Length	Flags
5.003	Value	Angle (degrees)	1 byte	C-WTU
5.003	Value status	Angle (degrees) feedback	1 byte	C-W-U
6.010	Value	Count impulses (-128..127)	1 byte	C-WTU
6.010	Value status	Count impulses (-128..127) feedback	1 byte	C-W-U
7.001	Value	Pulses	2 byte	C-WTU
7.001	Value status	Pulses feedback	2 byte	C-W-U
8.001	Value	Pulse difference	2 byte	C-WTU
8.001	Value status	Pulse difference feedback	2 byte	C-W-U
9.*	value	2 byte floating point value	2 byte	C-WTU
9.*	value status	2 byte floating point value feedback	2 byte	C-W-U
12.001	Value	Count impulses, unsigned	4 byte	C-WTU
12.001	Value status	Count impulses, unsigned, feedback	4 byte	C-W-U
13.001	Value	Count impulses, signed	4 byte	C-WTU
13.001	Value status	Count impulses, signed, feedback	4 byte	C-W-U
14*	Value	4 byte floating point value	4 byte	C-WTU
14*	Value status	4 byte floating point value feedback	4 byte	C-W-U

Music

The parameters for the music element are:

Invert play/pause	0 = Pause, 1 = Play or 1 = Pause, 0 = Play
Activate volume control	Activates/deactivates the volume control
Activate next/previous title	Activates/deactivates next/previous title
Value for previous title	Activated: Sends 1, deactivated: Sends 0
Activate title information	Activates/deactivates title and artist

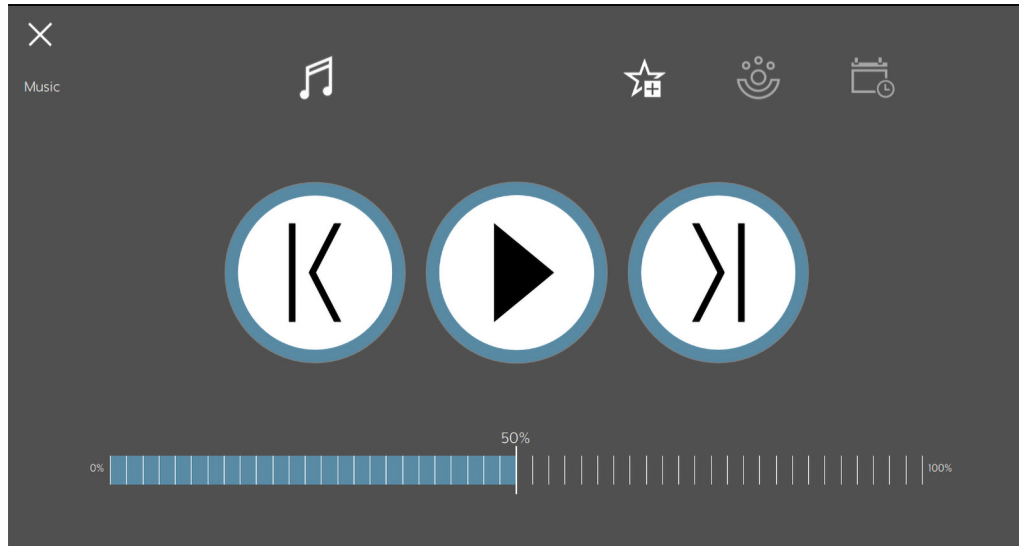

Fig. 90: Elements and objects – Music

DPT	Name	Function	Length	Flags
1.001	Play/Pause	Switch	1 bit	C-WTU
1.001	Play/Pause Status	Switch feedback	1 bit	C-W-U
5.001	Volume	Percent (0..100%)	1 byte	C-WTU
5.001	Volume status	Percentage feedback (0..100%) feedback	1 byte	C-W-U
1.001	Next title	Switch	1 bit	C-WTU
1.001	Previous title	Switch	1 bit	C-WTU
16*	Title name status	Character set	14 byte	C-W-U
16*	Title artist status	Character set	14 byte	C-W-U

Command button

This element functions like a physical push-button.

The following parameters are available for the element:

Icon	Select an icon from the library
"Button pressed" value	Value to be sent on pressing
"Button released" value	Value to be sent on releasing

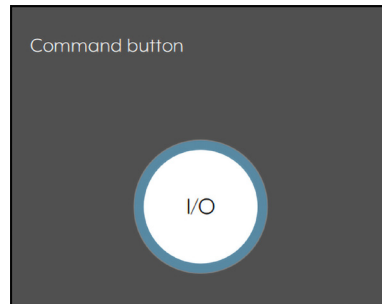

Fig.91: Elements and objects – Command button

DPT	Name	Function	Length	Flags
1.001	Value	Switch	1 bit	C-WTU
1.002	Value	Boolean	1 bit	C-WTU
1.003	Value	Enable	1 bit	C-WTU
1.004	Value	Increase	1 bit	C-WTU
1.005	Value	Alarm	1 bit	C-WTU
1.006	Value	Binary value	1 bit	C-WTU
1.007	Value	Step	1 bit	C-WTU
1.008	Value	Up/down	1 bit	C-WTU
1.009	Value	Open / Close	1 bit	C-WTU
1.010	Value	Start / Stop	1 bit	C-WTU
1.011	Value	Status	1 bit	C-WTU
1.012	Value	Inversion	1 bit	C-WTU
1.013	Value	Dimming send type	1 bit	C-WTU
1.014	Value	Input type	1 bit	C-WTU
1.015	Value	Reset	1 bit	C-WTU
1.016	Value	Confirmation	1 bit	C-WTU
1.017	Value	Trigger	1 bit	C-WTU
1.018	Value	Assignment	1 bit	C-WTU
1.019	Value	Window/door	1 bit	C-WTU
1.021	Value	Logic function	1 bit	C-WTU
1.022	Value	Scene	1 bit	C-WTU
1.023	Value	Roller shutter / blind mode	1 bit	C-WTU
1.024	Value	Day/night	1 bit	C-WTU
1.100	Value	Heating/cooling	1 bit	C-WTU
5.001	Value	Percent (0 .. 100%)	1 byte	C-WTU
5.003	Value	Angle (degrees)	1 byte	C-WTU
5.005	Value	Decimal factor (0..255)	1 byte	C-WTU
5.006	Value	Tariff (0..255)	1 byte	C-WTU
5.010	Value	Count impulses (0..255)	1 byte	C-WTU

Temperature, time and date



Fig. 92: Elements and objects – Temperature, time and date

DPT	Name	Function	Length	Flags
9.001	STATUS BAR Indoor temperature status	Temperature (°C) feedback	2 byte	C-W-U
9.001	STATUS BAR Outdoor temperature status	Temperature (°C) feedback	2 byte	C-W-U
10.001	SYSTEM Time	Time	3 byte	C-WTU
11.001	SYSTEM Date	Date	3 byte	C-WTU

Presence simulation

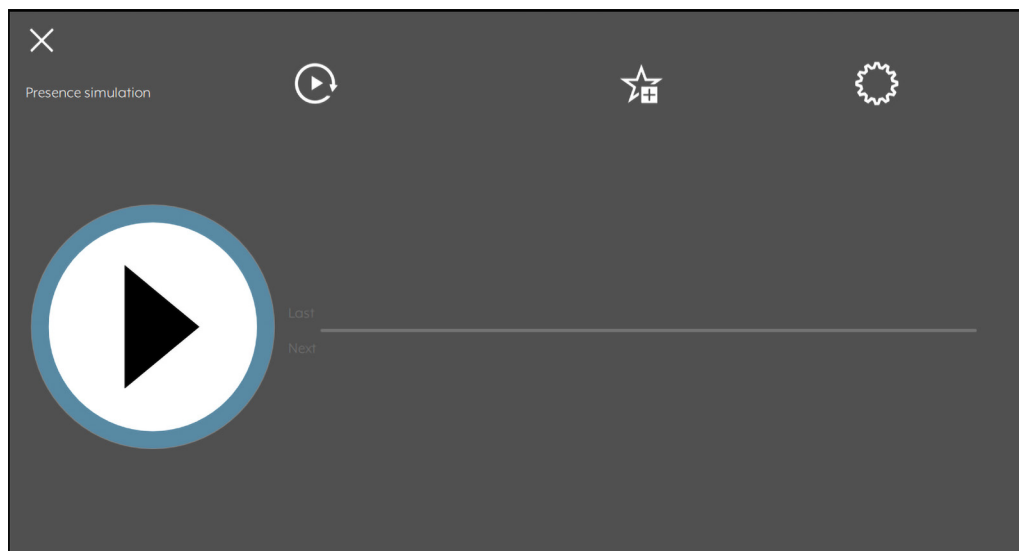

Fig. 93: Elements and objects – Presence simulation

DPT	Name	Function	Length	Flags
1.001	SYSTEM Presence simulation - Synchr. status	Switch	1 bit	C-WTU
1.001	SYSTEM Presence simulation - Synchr. status (status)	Switch feedback	1 bit	C-W-U

8 Cleaning

i The cleaning mode is started with the “Screencleaner” app.

Suitable cleaning agents:

Water, degreaser, glass cleaner, alcohol and isopropyl alcohol

Not suitable for cleaning:

Abrasive cloths or harsh detergents

- Start the cleaning mode or switch off the device to lock the touch screen.
- Apply cleaning agent or water to a cloth.
Do not apply directly to the device.
- Clean the front with a cloth.
Cleaning agent must not get into the device.
- Switch the device on again after cleaning or wait for the cleaning mode to end automatically after 30 seconds.

9 Technical data

Screen diagonal:	203 mm / 8"	
Resolution	1280 x 800 (WXGA)	
Aspect ratio	16:9	
Overall dimensions (W x H)	Smart Panel Adapter	225 x 145 mm 216 x 141 mm
Structure height	16 mm	
Installation depth	22 mm	
Power consumption	max. 16 W	
Power supply	DC 12 ... 32 V SELV via external power adapter	
Operating system	Android 6	
Processor	Cortex-A53	
Main memory	2 GB	
Mass storage	16 GB Flash	
USB connection	1 x USB 2.0 type A	
LAN connection	1 x 10/100/1000 Mbit/s	
KNX	KNX connection terminal	
KNX medium	TP 256	
Ambient temperature	0 ... +30 °C	
Atmospheric humidity	5 ... 80 % (no moisture condensation)	

10 Accessories

Power supply adapter	NT 2415 REG VDC
Installation box	EBG 24 SC 7 EBG

11 Terms and definitions

Term	Description
DCA (Device Configuration App)	Additional program for the ETS for commissioning. The DCA is displayed as an additional tab in the ETS. The DCA allows the import of the project file (*.ksp) into the ETS from the Smart Panel Designer.
DPT (Data point types)	Standardised format for communication objects. Allows the evaluation of the data of a communication object.
Pairing	Creation of an initial connection between two devices. The Smart Panel can be connected to a mobile terminal (smartphone, tablet, etc.). This allows remote control using the JUNG Smart Vision app. For this, both devices must be in the local network (LAN, Wi-Fi).

12 Warranty

The warranty follows about the specialty store in between the legal framework as provided for by law.