

Leakage sensor

Art. no.: LES01

Operating instructions

1 Safety instructions



Electrical devices may only be mounted and connected by electrically skilled persons.

Serious injuries, fire or property damage possible. Please read and follow manual fully.

Danger of electric shock. During installation and cable routing, comply with the regulations and standards which apply for SELV circuits.

These instructions are an integral part of the product, and must remain with the end customer.

2 Device components

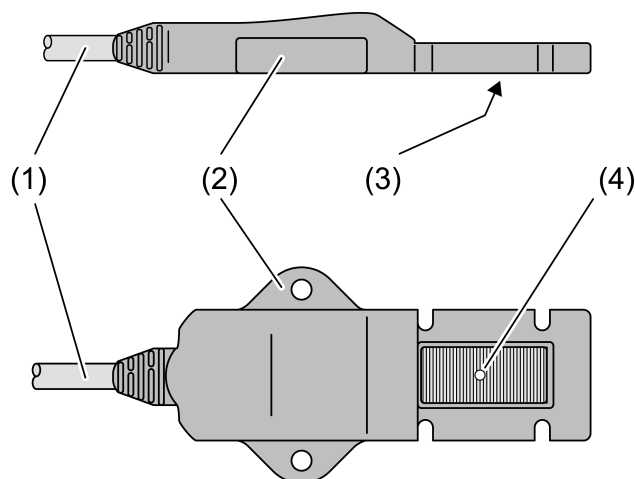

Figure 1

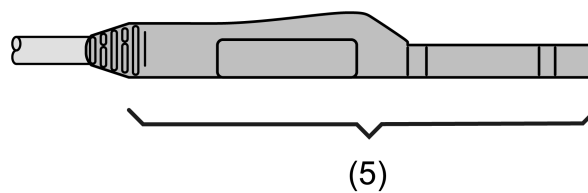

Figure 2

- (1) Connecting cable
- (2) Fixing strap
- (3) Sensor surface
- (4) Ventilation opening
- (5) Supporting surface

3 Function

Intended use

- Detection of water penetration and leaks
- Connection to suitable binary inputs
- Fitting to the surface to be monitored

Function of the leakage sensor

The device monitors the electrical conductivity between the conductive coatings on the sensor surface. If it is dampened with water, the device detects the change and signals it.

- i** The device cannot prevent water from leaking, but detects and registers it early, so that the impact of water damage can be kept minor.
- i** The sensor surface can be damaged if it comes into contact with aggressive media (e.g. detergent solutions, scrubbing brines or acidic condensation from condensing boilers). Check the sensor area (3) every alarm. In case of significant damage from corrosion replace the device.

Application examples

In bathrooms or wet rooms:

- Below or next to the bathtub or shower
- Under the wash basin or behind vanities

In the kitchen area:

- Under the kitchen unit
- Under the dishwasher
- Under the sink

In utility rooms or functional spaces:

- Below or behind washing machines
- In boiler rooms
- In supply shafts with water pipes
- In cellar rooms with a risk of backflow

In living areas:

- Below or behind aquariums
- In the heating manifold of underfloor heating systems

4 Information for electrically skilled persons

4.1 Fitting and electrical connection

Fitting the leakage sensor

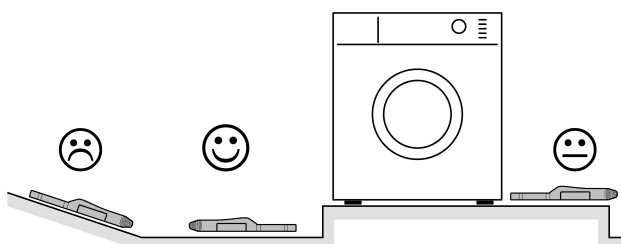

Figure 3: Appropriate and inappropriate locations for fitting

- i** Do not place the device on sloping surfaces, ridges or pedestals (Figure 3). Look for an appropriate installation location at which escaping water can be detected early.
 - Place the device directly on the surface that is to be monitored. The sensor surface (3) must point downwards.
 - Mount the device on the supporting surface, e.g. with a screw assembly, torque max. 0.4 Nm
- i** The vent opening (4) may not be used to mount the device.
- i** For proper function, liquid must be able to reach the sensor surface (3).

- i** Do not mount the device to the substrate with sealing compound (silicone, acrylic or similar).
- Fit the connecting cable, e.g. with nail clamps.
- i** The vent opening (4) supports the sensor function and should be free of dirt.

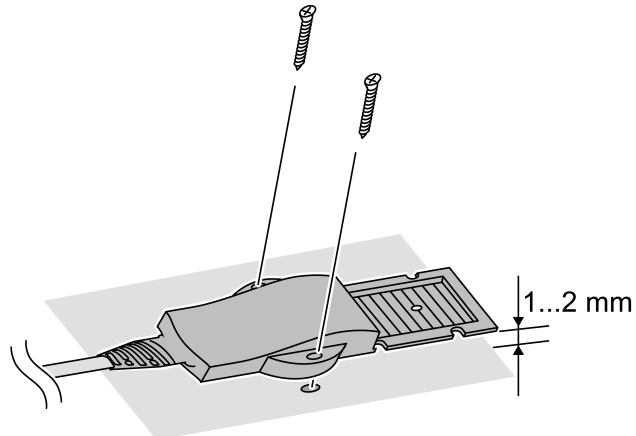

Figure 4

Connecting the leakage sensor

The device is directly connected to an evaluation unit and supplied by it. The signaling takes place by short-circuiting the supply voltage.

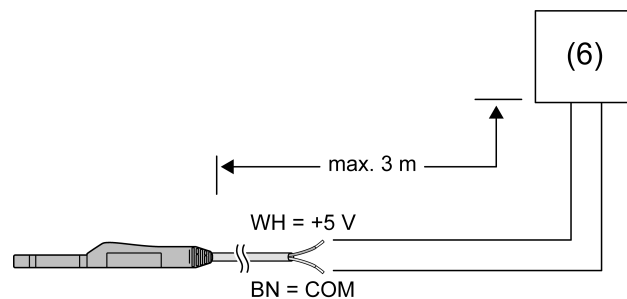

Figure 5

- Connect the device to an evaluation unit (6) that supplies and monitors the device.
- Observe the polarity:
White = +
Brown = - / COM

4.2 Commissioning

Debounce time of the evaluation unit to be set:

The ideal debounce time for this sensor is 138 ms. If this debounce time cannot be set, the maximum possible debounce time should be set.

If the dew point/leakage sensor is parameterised in the evaluation unit under “Functionality of the inputs”, the debounce time is set automatically.

5 Technical data

Rated voltage	DC 3.3 ... 5 V SELV
Current consumption	typ. 0.5 mA
Short-circuit current	max. 100 mA
Protection class	III

Ambient temperature	0 ... +50 °C
Storage/transport temperature	-40 ... +100 °C
Connecting cable	2 m
Degree of protection	IP 67

6 Warranty

The warranty is provided in accordance with statutory requirements via the specialist trade.

ALBRECHT JUNG GMBH & CO. KG

Volmestraße 1
58579 Schalksmühle
GERMANY

Telefon: +49 2355 806-0
Telefax: +49 2355 806-204
kundencenter@jung.de
www.jung.de